



Integrators' Reference Manual

**For
ViewStation® EX,
ViewStation® FX,
and VS4000**

Trademark Information

Polycom® and the Polycom logo design are registered trademarks of Polycom Inc. ARENA™, Global Management System™, ImageShare™, iPower™, LimeLight™, MGC Manager™, PathNavigator™, Polycom Office™, Polycom OneDial™, ViewStation™, ViaVideo™, Visual Concert DC™, Visual Concert FX™, Visual Concert PC™, WebOffice™, and WebCommander™ are trademarks of Polycom, Inc. in the United States and various other countries.

Internet Explorer™, NetMeeting®, Windows®, and Windows NT® are either registered trademarks or trademarks of Microsoft Corporation in the United States and/or other countries.

Intel®, Pentium®, and Celeron® are registered trademarks and TeamStation™ is a trademark of Intel Corporation.

Adobe® Acrobat® is a registered trademark of Adobe Systems Incorporated.

ADTRAN® is a registered trademark of ADTRAN, Inc.

QuickTime™ is a trademark of Apple Computer, Inc.

Netscape® Navigator® is a registered trademark of Netscape Communications Corporation.

IP/TV® is a registered trademark of Cisco Systems, Inc.

All other trademarks are the property of their respective owners. Every effort has been made to ensure that the information in this manual is accurate. Polycom, Inc. is not responsible for printing or clerical errors. Information in this document is subject to change without notice.

© 2003 Polycom, Inc. All rights reserved.

Polycom Inc.
4750 Willow Road
Pleasanton, CA 94588-2708
USA

No part of this document may be reproduced or transmitted in any form or by any means, electronic or mechanical, for any purpose, without the express written permission of Polycom, Inc. Under the law, reproducing includes translating into another language or format.

As between the parties, Polycom, Inc. retains title to, and ownership of, all proprietary rights with respect to the software contained within its products. The software is protected by United States copyright laws and international treaty provision. Therefore, you must treat the software like any other copyrighted material (e.g. a book or sound recording).

Every effort has been made to ensure that the information in this manual is accurate. Polycom, Inc. is not responsible for printing or clerical errors. Information in this document is subject to change without notice.

Contents

Chapter 1 - About this Manual 1

Conventions Used in this Manual	2
Glossary	2

Chapter 2 - Technical Information..... 11

System Descriptions	12
Technical Specifications	12
RS-232 Interface.....	20
Quad BRI Network Interface Module.....	22
Indicators on the Quad BRI Network Interface Module	22
Quad BRI Cabling.....	23
NT-1 Information.....	24
ISDN Switches.....	25
Automatic Quad BRI Software Update.....	25
PRI Network Interface Module for ViewStation FX and VS4000	26
Indicators on the PRI Network Interface Module	27
PRI Cabling.....	29
Channel Selection	30
PRI E1 Channel Information	30
Dedicated Full PRI T1 or E1 Line	30
V.35/RS-449/RS-530 Network Interface Module.....	31
Indicators on the V.35/RS-449/RS-530 Network Interface Module	31
V.35/RS-449/RS-530 Cabling	32
Serial Interface Control Signals	38
State Machine	39
Crypto Resync.....	44
Other Elements of a Typical Deployment	45

Chapter 3 - Before You Deploy..... 47

Predeployment Overview.....	48
Video Network Security.....	49
Best Practices	50
Predeployment Planning	51
LAN/WAN Considerations.....	52

Capacity Planning	53
Call Processing Considerations	54
Gatekeeper Identifier	55
Default Gatekeeper	55
Call Routing Mode	55
Developing the Dial Plan.....	55
Services	57
Administration, Policies, and Routing.....	58
Network Topology	59
Neighbor gatekeepers.....	59
Addressing	60
Zones and Zone Prefixes	60
Entity Addressing	61
Rules for Assigning Prefixes and Numeric Aliases	62
Service Plans	62
System Services	63
ISDN Requirements.....	63
ISDN PRI.....	63
Determining Usage	65
PBX Network Configuration	65
ISDN BRI.....	65
DCP (Digital Communication Port) On Lucent Definity ECS.....	68
Network Configuration.....	68
Installation.....	68
Configuration.....	69
Site Considerations.....	72
Predeployment Worksheet.....	74

Chapter 4 - Installing Videoconferencing Systems 77

The Deployment Process	78
Installation Procedures	79
Installing Network Interface Modules	79
Quad BRI Network Interface Module	79
NT-1 Device	80
Cables Used with the Quad BRI Network Interface Module	80
Installation.....	80
Installing a PRI Network Interface Module	81
External Power Supply.....	81
Channel Service Unit	82
ADTRAN Atlas 800 Plus E1 Module.....	82
If You Are Connecting to a PBX.....	83
Cables Used with the PRI Network Interface Module	83

Installation	84
Installing a V.35/RS-449/RS-530 Network Interface Module	85
Cables Used with the V.35/RS-449/RS-530 Network Interface Module ...	85
Installation	86
Network Configuration.....	88
On a PRI T1 Network: Configuring the CSU.....	88
Firewall and NAT Issues	89
Configuring the System to Operate Behind a Firewall	89
Configuring the System to Operate Behind a NAT.....	90
Connecting the System to a PC	91
PC Requirements	91
Connecting the PC to the LAN Through the ViewStation EX, ViewStation FX, or VS4000.....	92
Connecting the System to a PC off the LAN	94
Placing Test Calls	96

Chapter 5 - Supporting Advanced Users 97

Multiple-Monitor Mode	98
RS-232 Interface.....	105
RS-232 Control Mode	105
RS-232 Pass-Thru Mode.....	105
Flow Control.....	106
Configure the System for RS-232 Operation.....	107
Command Line Interface (CLI).....	107

Chapter 6 - Testing and Troubleshooting 109

Indicator Lamps	109
Indicator Lamps on the PRI Network Interface Module	110
Indicator Lamps on the Quad BRI Network Interface Module	111
Indicator Lamps on the V.35/RS-449/RS-530 Network Interface Module.....	112
Fault Isolation	113
ISDN Error Codes	114

Appendix A - System Interoperability..... 121

Appendix B - ViewStation Series Cables 125

Board Room and Custom Room Systems	125
--	-----

Medium and Large Room Systems 128
Small Room Systems..... 130

Safety and Legal Notices 133

Index 135

List of Figures

Figure 2-1.	RS-232 Cable for ViewStation EX and FX	20
Figure 2-2.	RS-232 Cable for VS4000.....	21
Figure 2-3.	Keyed RJ-45 Cable, System to Network Interface Module.....	23
Figure 2-4.	Standard RJ-45 Cable, Network Interface Module to Network.....	24
Figure 2-5.	Keyed RJ-45 Cable, System to Network Interface Module.....	29
Figure 2-6.	Standard RJ-45 Cable, Network Interface Module to Network.....	29
Figure 2-7.	HD-44M to RS-366/V.35 “Y” Cable Diagram	32
Figure 2-8.	Pinout to the HD-44M to RS-366/V.35 “Y” Cable	33
Figure 2-9.	HD-44M to RS-449/RS-422 “Y” Cable Diagram	34
Figure 2-10.	Pinout to the HD-44M to RS-449/RS-422 “Y” Cable	35
Figure 2-11.	Ascend HD-44M to HD-44M Cable Diagram.....	36
Figure 2-12.	Pinout for the Ascend HD-44M to HD-44M Cable	36
Figure 2-13.	RS-530 Cable Diagram and Pinout.....	37
Figure 3-1.	The Predeployment Process.....	48
Figure 3-2.	Network Configuration (No PBX)	66
Figure 3-3.	Network Configuration (Behind PBX)	66
Figure 4-1.	The Deployment Process	78
Figure 4-2.	Installing Network Interface Modules	79
Figure 4-3.	Quad BRI Network Interface Module (Peripheral Side).....	80
Figure 4-4.	Quad BRI Network Interface Module (Network Side)	81
Figure 4-5.	PRI Network Interface Module (Peripheral Side).....	84
Figure 4-6.	PRI Network Interface Module (Network Side)	84
Figure 4-7.	V.35/RS-449/RS-530 Network Interface Module (Peripheral Side)	86
Figure 4-8.	V.35/RS-449/RS-530 Network Interface Module (Network Side).....	86

List of Tables

Table 2-1.	Electrical and Physical Specifications	12
Table 2-2.	Connectivity	13
Table 2-3.	Video Standards Supported.....	14
Table 2-4.	Video Signal Formats.....	14
Table 2-5.	Video Input/Output Electrical Specifications.....	15
Table 2-6.	Video Resolution, Frame Rate, and Error Correction	15
Table 2-7.	Cameras and Displays	16
Table 2-8.	Audio Input/Output Electrical Characteristics	16
Table 2-9.	Audio Features.....	17
Table 2-10.	Microphone Pods.....	17
Table 2-11.	Call Capabilities.....	18
Table 2-12.	User Interface	19
Table 2-13.	Quad BRI Indicator Lamps	22
Table 2-14.	Sample NT-1 Settings.....	24
Table 2-15.	ISDN Switch Types and SPID Allocations.....	25
Table 2-16.	PRI T1 and E1 Network Interface Modules.....	26
Table 2-17.	PRI Network Side Indicator Lamps.....	27
Table 2-18.	PRI Peripheral Side Indicator Lamps	28
Table 2-19.	V.35/RS-449/RS-530 Peripheral Side Indicators	31
Table 2-20.	V.35/RS-449/RS-530 Network Side Indicator Lamps	32
Table 2-21.	Serial Interface Control Signals	38
Table 2-22.	Dial-Out State Machine.....	39
Table 2-23.	Inbound Call State Machine	40
Table 2-24.	Non-Dialed User-Initiated Call State Machine	42
Table 2-25.	Non-dialed Network-Initiated Call State Machine	43
Table 3-1.	Latency, Jitter, and Packet Loss	50
Table 3-2.	Bandwidth Requirements.....	53
Table 3-3.	Zone Identifiers and Neighbor Gatekeepers	61
Table 3-4.	ISDN PRI Requirements	64
Table 3-5.	Example Configuration, Data Module 1	70
Table 3-6.	Example Configuration: Channel 1, Secondary Data Module 2.....	70
Table 3-7.	Site Considerations.....	72
Table 4-1.	Firewall Ports to Open for Videoconferencing.....	89
Table 5-1.	Expected Display for Each Monitor	98
Table 5-2.	RS-232 Control and Pass-Thru Modes.....	106
Table 6-1.	PRI indicator lamps - Network side	110
Table 6-2.	PRI indicator lamps - Peripheral side	111
Table 6-3.	Quad BRI Indicator Lamps	111

Table 6-4.	V.35/RS-449/RS-530 Indicator Lamps - Network Side.....	112
Table 6-5.	V.35/RS-449/RS-530 Indicator Lamps - Peripheral Side	112
Table 6-6.	Fault Isolation	113
Table 6-7.	ISDN Call Status Codes.....	114
Table A-1.	H.320 Endpoints	121
Table A-2.	H.323 Endpoints	122
Table A-3.	H.323 MCU Interoperability	123
Table A-4.	Gateway/Gatekeeper Interoperability	123
Table A-5.	NAT and Firewall Interoperability.....	124
Table B-1.	Cables for VS4000.....	125
Table B-2.	Cables for ViewStation EX and ViewStation FX.....	126
Table B-3.	Cables for Upgrades to ViewStation EX, ViewStation FX, and VS4000....	126
Table B-4.	Cables for ViewStation EX, ViewStation FX, and VS4000 Accessories	127
Table B-5.	Additional Cables for ViewStation EX, ViewStation FX, and VS4000	127
Table B-6.	Cables for ViewStation H.323.....	128
Table B-7.	Cables for ViewStation MP.....	129
Table B-8.	Cables for ViewStation MP DCP.....	129
Table B-9.	Cables for Upgrading ViewStation Models (Except FX).....	130
Table B-10.	Cables for ViewStation SP 128.....	130
Table B-11.	Cables for ViewStation 128.....	131
Table B-12.	Cables for ViewStation SP 384.....	131

1

About this Manual

This chapter provides information to help you use the rest of the manual.

This manual covers the following topics:

Topic	Page
Technical Information	11
Before You Deploy	47
Installing Videoconferencing Systems	77
Supporting Advanced Users	97
Testing and Troubleshooting	109

Conventions Used in this Manual

The following typographic conventions are used in this manual:

- ❑ Links that allow you to jump to other sections of this manual are [blue](#).
- ❑ File path names and commands you type in command lines are shown in *this font*.
- ❑ Screen names and elements are shown in **bold type**.
- ❑ Navigation through sequences of screens or menu selections is shown in this form: **First selection > second selection > third selection**.

Glossary

4CIF	4 x CIF (Common Intermediate Format). A video format providing resolution of 704 x 576 pixels. See also CIF, QCIF, 16CIF.
16CIF	16 x CIF (Common Intermediate Format). A video format providing resolution of 1408 x 1152 pixels. See also CIF, 4CIF, QCIF.
ADSL	Asymmetrical Digital Subscriber Line. Used to transmit digital data over telephone wires at up to six megabits per second.
AIS	Alarm Indication Signal. This indicates that there is a problem upstream.
Analog Line	A telephone line that transmits and receives analog signals. An analog signal is a true electrical representation of the original source audio.

ARJ	H.323 Admission Reject Message. This message is from the Gatekeeper, rejecting the endpoint's request to connect to another endpoint.
ARQ	H.323 Admission Request Message. This message is from an endpoint to the Gatekeeper requesting a connection to another endpoint.
Automatic Voice Tracking	A feature on Polycom ViewStation® systems that allows the camera to point toward the person speaking.
B channel	Bearer channel. B channels carry audio and video.
Bandwidth	The data-carrying capacity of a network connection, given in terms of speed. For example, an Ethernet link is capable of moving 10 million bits of data per second. A Fast Ethernet link can move 100 million bits of data per second – it has 10 times more bandwidth.
Bonding Calls	In ISDN BRI and PRI transmissions, bonding refers to joining two or more B channels together to get one channel whose bandwidth is equal to the sum of the bonded channels' bandwidths. Using a Quad BRI interface, up to 8 channels may be bonded. T1 allows up to 23 channels to be bonded, and E1 allows up to 30.
BRI	ISDN Basic Rate Interface. Provides two B channels and one 16 Kbps D channel (2B+D) for a total of 144 Kbps, 128Kbps of which is available for the audio and video content of the call.
Bridge	A device that passes packets between network segments that use the same communications protocol. If a packet's destination is within the sender's own network segment, the bridge keeps the packet local. Otherwise, the bridge passes the packet to the network backbone. Also, in videoconferencing, a Multipoint Control Unit. See MCU.
Broadcast	A one-to-many transmission that can be received by anyone connected to the network.

CIF	Common Intermediate Format, also called FCIF. A video format providing resolution of 352 x 288 pixels. See also QCIF, 4CIF, 16CIF.
Client	A networked PC or terminal that shares services with other PCs. These services are provided by a server.
Conference Call	Any call that establishes all-way communication between three or more endpoints.
CPE	Customer Premises Equipment.
CRC	Cyclic Redundancy Check.
CSU	Channel Service Unit.
D channel	Data channel. The D channel carries the call protocol signals.
Data Conferencing	Enables people in different locations to work on the same document via networked computers. Also called collaborative computing.
DB-25	The standard 25-pin connector used for RS-232 serial data communications.
DCE	Data Communications Equipment.
DHCP	Dynamic Host Configuration Protocol. DHCP servers permit multiple devices to share a group of IP addresses, assigning IP addresses to specific devices as needed.
DID	Direct Inward Dial.
Digital Line	A telephone line that carries audio encoded as a digital signal, which must be decoded to analog at the destination. ISDN uses digital signaling.
Downstream	Closer to the endpoint. For example, the peripheral side of a network interface module is downstream of the network side.
DSL	Digital Subscriber Line. Uses existing copper telephone lines and connects to the telephone company's central office. See also ADSL.

Endpoint	A site, videoconferencing system, gateway, or MCU.
Ethernet	10 Mbps or 100 Mbps LAN technology based on CSMA/CD.
Far End	The party or parties to whom you place a call.
Fast Ethernet	100 Mbps LAN technology based on CSMA/CD.
FCIF	Full CIF. See CIF.
Firewall	A network node set up as a boundary to prevent traffic from one segment to cross over into another.
fps	Frames per second. Note that there are two fields per frame.
FTP	File Transfer Protocol. A part of the chief Internet protocol stack or group (TCP/IP) used for transferring files.
Full Duplex	Transmission in two directions at once (bidirectional communication). In a full-duplex call, all participants can both talk and hear others at the same time.
Gatekeeper	An H.323 device that provides address translation, control access, and bandwidth management to the LAN.
Gateway	An H.323 device that provide real-time, two-way communication between dissimilar (H.323 and H.320) endpoints operating across dissimilar networks.
GUI	Graphical User Interface. A user interface that incorporates icons, command menus, and other graphical elements. GUI-based software requires the use of a mouse, touch-screen, or other pointing device.
H.320	ITU-T videoconferencing standards for ISDN.

H.323	ITU-T videoconferencing standard for IP. H.323 includes the H.225, H.245, G.711, G.722, G.723.1, G.728, and G.729 standards.
IMUX	Inverse Multiplexer. See Quad BRI network interface module.
IP	Internet Protocol. A unique IP address identifies every computer connected to the Internet. IP addresses take the form 255.255.255.255; each of the four numbers is in the range 0 to 255.
IP Precedence	Audio, video and far end camera control packets may be assigned a higher priority than other network traffic. Precedence 4 is recommended for multimedia data. By default, IP precedence is disabled by most routers and is not enabled on the Internet.
ISDN	Integrated Services Digital Network. Digital telephone service, available at 128 Kbps (BRI), 1.544 Mbps (PRI), and Broadband ISDN (2 Mbps - 600 Mbps).
ISP	Internet Service Provider.
LAN	Local Area Network. A network that serves users within a confined geographical area. It includes servers, workstations, a network operating system and a communications link.
LED	Light-Emitting Diode. An indicator lamp.
MCU	Multipoint Conferencing Unit or Multi Control Unit. Hardware that allows three or more videoconferencing systems to participate in an interactive multi-way conference.
Multicast	A one-to-many transmission that goes to designated recipients only.
Multipoint call	A call in which more than two sites participate.
Near End	Your end or local end site of the videoconference.
Network side	The portion of a network interface module that connects to the network. See also Upstream.

NFAS	Non-Facility Associated Signalling.
NT-1	Network Termination type 1. The device that converts the ISDN BRI U interface from the telecommunications service provider to the S/T interface used by ISDN products and systems.
Pan	Move the camera to the left or right.
PBX	Private Branch eXchange. A private telephone switching system connected to common lines from one or more central offices. Most PBXs allow analog extensions on the system, allowing access to special features such as conferencing and transferring to analog devices. If you are using a telephone connected to a PBX, typically you will be required to dial 9 to gain access to an outside line.
Peripheral side	The portion of a network interface module that connects to the videoconferencing system. See also Downstream.
Point-to-point call	A call between two sites.
POTS	Plain Old Telephone Service. See PSTN.
PRI	Primary Rate Interface.
Private Branch Exchange	See PBX.
PSTN	Public Switched Telephone Network. The voice telephone network accessible to all those with telephones and access privileges.
PTZ	Pan/Tilt/Zoom. Describes the cameras supplied as part of the ViewStation EX, ViewStation FX, and VS4000 systems.
QCIF	Quarter CIF (Common Intermediate Format). A video format providing resolution of 176 x 144 pixels. See also CIF, 4CIF, 16CIF.

QoS	Quality of Service. This allows guaranteed bandwidth and packet delivery between endpoints over a packet network.
RAI	Remote Alarm Indication.
RJ-11	A six-conductor modular jack. RJ-11 connectors are used on all standard telephones in the US for connecting to the PSTN.
RJ-45	An eight-conductor modular jack commonly used for data lines such as LAN connections.
RJ-9	A four-conductor modular jack commonly used for telephone handsets. Polycom uses RJ-9 connectors for all of the Extension microphone connections.
Router	A networking device with ports for connection to hubs and switches. It provides central connectivity and security for multiple workgroups and LANs.
Server	A computer or software that provides services to clients — for example, file storage (file server), programs (application server), or printer sharing (print server). See also client.
Site	A location or a system; the term implies that rooms and people are also included. Two sites participate in a point-to-point call. Multiple sites participate in a multipoint call.
Streaming	A technology that allows an audio or video file to start playing on your computer before the entire file has finished downloading.
Tilt	Move the camera up or down.
UI	User Interface. The controls that let you interact with equipment or software. See also GUI.
UPS	Uninterruptable Power Supply.
Upstream	Farther from the endpoint. For example, the network side of a network interface module is upstream of the peripheral side.

WAN	Wide Area Network. Business with LANs at more than one location may use the public carrier network to carry data between these locations. Typical WAN services provided by the public carrier are Frame Relay, X.25, and ISDN for carrying data.
Whiteboard	Software that allows you to share and annotate images.
Zoom	Adjust the area shown on the screen using the camera's telephoto and wide-angle capabilities.

2

Technical Information

This chapter provides descriptions and technical information about the ViewStation EX, ViewStation FX, and VS4000 systems.

This chapter covers the following topics.

Topic	Page
System Descriptions	12
Other Elements of a Typical Deployment	45

System Descriptions

The Polycom ViewStation EX and ViewStation FX systems are set-top videoconferencing systems designed for conference rooms. The Polycom VS4000 system is a rack-mounted videoconferencing system designed for large conference rooms or board rooms. These systems may be purchased with the following optional network interface modules:

- ❑ Quad BRI : allows up to four ISDN lines to be multiplexed together to create a higher-bandwidth connection to the far-site device. Each ISDN line adds 128 Kbps to the available data rate.
- ❑ V.35/RS-449/RS-530: supports V.35, RS-449, and RS-530 protocols, depending on the cable used. This interface module allows you to connect the system to third-party network interfaces.

In addition, a PRI network interface module is available with the ViewStation FX and VS4000 systems. This module allows you to make video calls over ISDN T1 and E1 lines.

Technical Specifications

The following table gives electrical and physical specifications for the ViewStation EX, ViewStation FX, and VS4000 systems.

Table 2-1. Electrical and Physical Specifications

Parameter	ViewStation EX and FX	VS4000
Power supply type	Auto-sense	
Line voltage	90 to 260 VAC continuous	
Line frequency	47 to 63 Hz continuous	
Power consumption	40 W	
Case style	Set-top	Rack-mount
Physical dimensions	33 x 20 x 15 cm (13 x 8 x 6 in.)	46.7 x 43.8 x 8.8 cm (18.4 x 17.2 x 3.5 in.)
Weight	2.7 kg (6 lbs)	4.7 kg (10.3 lbs)

The following table describes the network interfaces available.

Table 2-2. Connectivity

Network interface	Connectivity provided
LAN/WAN	Supports—TCP/IP, DNS, WINS, SNMP, DHCP, ARP, WWW, FTP, Telnet (2) 10/100 Mbps Ethernet ports T.120 interface with ShowStation® IP, WebStation™ and Microsoft® NetMeeting®
Telephony	Quad BRI (Basic Rate Interface) PRI (Primary Rate Interface) T1 — not available for ViewStation EX PRI E1 — not available for ViewStation EX V.35/RS449/RS-530; support direct connect or RS-366 dialing Supports H.331 broadcast mode
Data port	RS-232 control port/data communications port (1200 baud to 115 K baud asynchronous)

ViewStation EX, ViewStation FX, and VS4000 are Cisco AVVID certified.

The following table lists the supported video standards.

Table 2-3. Video Standards Supported

Standard	Supported
Videoconferencing	H.320 p x 64 H.323
Video standards	H.261 + Annex D H.263 + Annexes F, I, J, L, T, U, u ITU 60 fields/sec
Other ITU standards	H.221 BONDING, mode 1 H.225, H.245 H.281 far-end camera control H.331 broadcast mode

The following table gives information about the video signal formats.

Table 2-4. Video Signal Formats

Input/Output	Signal format	
	ViewStation EX and FX	VS4000
Video inputs (NTSC or PAL)		
Main camera		S-video and composite
Second camera	S-video	S-video and composite
Document camera	S-video	S-video and composite
VCR (playback)	Composite	Composite
Video outputs (NTSC or PAL)		
Main display	S-video and composite	S-video and composite
Additional displays	S-video	S-video and composite
VCR out (recording)	Composite	Composite
VGA out	Up to 1280 x 1024	
SXGA out	Up to 1280 x 1024	Up to 1280 x 1024

The following table gives electrical specifications for the video inputs and outputs.

Table 2-5. Video Input/Output Electrical Specifications

Parameter	Value/format
Impedance	75 Ω
Signal amplitude	1.0 V _{pp} typical
Coupling	DC

The following table gives other video specifications for the ViewStation EX, ViewStation FX, and VS4000 systems.

Table 2-6. Video Resolution, Frame Rate, and Error Correction

Parameter	Value/format
Video format	NTSC or PAL
Video resolutions	QCIF (176 x 144) CIF (352 x 288) 4CIF (704 x 576) TV-quality wide-screen (letterbox)
Graphics resolutions, slide transmission	H.261 mode: 4CIF (704 x 576) H.263 mode: 16CIF (1408 x 1152)
Graphics resolution, local display	up to 1280 x 1024
Frame rate	NTSC: 30 frames/second (60 fields/second) PAL: 25 frames/second (50 fields/second)
Error correction	Polycom Video Error Concealment (PVEC) ^a

a. PVEC is activated and deactivated automatically, as needed. Video quality degradation with the PVEC feature active may indicate that your IP network is not functioning properly. At the time of publication, PVEC is not available in dual stream mode or standards-based 60-field video.

The following table gives camera and display information.

Table 2-7. Cameras and Displays

Parameter	ViewStation EX and FX	VS4000
Main camera	Integrated Sony EVI-10	External Sony EVI-D10
Main camera features	65° field of view 12 x Zoom; f=4.2 to 42 mm F=1.85 to 2.9 mm Auto focus Automatic white balance	
Main camera presets	10	
Far camera presets	10	
Tracking	Voice tracking Track to presets	
Auto-PIP system	Auto-on, auto-swap, auto-off	

The following table gives electrical specifications for the audio inputs and outputs.

Table 2-8. Audio Input/Output Electrical Characteristics

Parameter	Value/format
Input	
Impedance	10 K Ω minimum
Signal amplitude	1.0 V _{pp} full-scale (expected)
Coupling	AC
Output	
Impedance	800 Ω maximum
Signal amplitude	1.0 V _{pp} full-scale (typical)
Coupling	AC

The following table gives information about audio features.

Table 2-9. Audio Features

Parameter	Value/format
Audio codecs ^a	G.711, G.722, G.722.1 ^b , G.728
Mode	Full duplex
Gain control	Automatic
Noise suppression	Automatic
Echo cancellation	Instant adaptation

a. The protocol used depends on the protocols supported by the opposite endpoint and on the line rate. Audio protocol is selected automatically to provide optimum audio clarity.

b. Provides enhanced frame loss compensation.

The following table gives information about the microphone pods supplied with the ViewStation EX, ViewStation FX, and VS4000 systems.

Table 2-10. Microphone Pods

Parameter	Value/description
Pick-up elements	3 hypercardioid pressure-zone microphones
Coverage	360°
Placement	Minimum 6 ft (1.8 m) from speakers Minimum 15 ft (4.6 m) from any other microphone

The following table gives information about multipoint calling.

Table 2-11. Call Capabilities

Feature	Capability
Maximum data rate	ViewStation EX: 768 Kbps ViewStation FX and VS4000: 2 Mbps
Local plus three other sites	ViewStation FX and VS4000: 384 Kbps ViewStation EX: 256 Kbps
Local plus two other sites	ViewStation FX and VS4000: 512 Kbps ViewStation EX: 384 Kbps
Cascading (H.320 only)	Up to 10 sites at 384 Kbps each, plus audio only to four other sites
Mixed-protocol dialing (H.320 and H.323)	Local plus three other sites, through internal MCU
Inbound calling	Sites using either H.320 (ISDN) or H.323 (IP) can dial in to an existing call
Integrated speakerphone (where approved)	Third-party audio add-in Point-to-point calling Multipoint calling
Video streaming	Live multicast to Cisco IP/TV® viewer or Apple QuickTime® player Start and stop the stream using Polycom browser interface

The following table gives information about the systems' user interfaces.

Table 2-12. User Interface

Feature	Capability
Languages	English, French, German, Spanish, Italian, Portuguese, Norwegian, Chinese, Japanese
Control system	Hand-held, ergonomically designed remote control Infrared receiver (external unit for VS4000, integrated in ViewStation EX and FX) On-screen graphical user interface Web browser interface (requires Microsoft Internet Explorer® or Netscape Navigator®)
Closed caption support	Three lines of text
Presentation and collaboration tools	PolycomSNAP™ screen capture tool pcPresent™ conversion tool for Microsoft PowerPoint® files
Collaboration accessories	Visual Concert FX™ Visual Concert PC™
API	ARENA™ API (Enables custom integration with remote devices such as touchscreen panels through RS-232 or Telnet interfaces)

RS-232 Interface

The RS-232 interface allows users to connect a ViewStation EX, ViewStation FX, or VS4000 to a PC. This provides a means of access to the ARENA API, which allows users to automate some of the systems' control features. Refer to the *ViewStation EX, ViewStation FX, and VS4000 ARENA API Programmer's Guide* for information about this API.

The RS-232 interface also makes it possible to use the system as a peripheral device for an RS-232 host.

Figure 2-1 shows the RS-232 cable for the ViewStation EX and Viewstation FX systems.

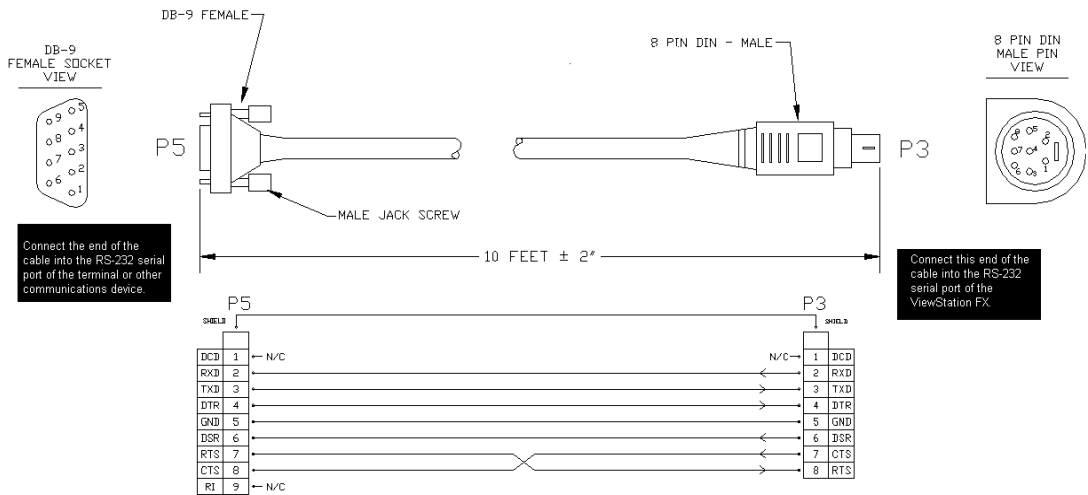

Figure 2-1. RS-232 Cable for ViewStation EX and FX

Figure 2-2 shows the RS-232 cable for the VS4000 system.

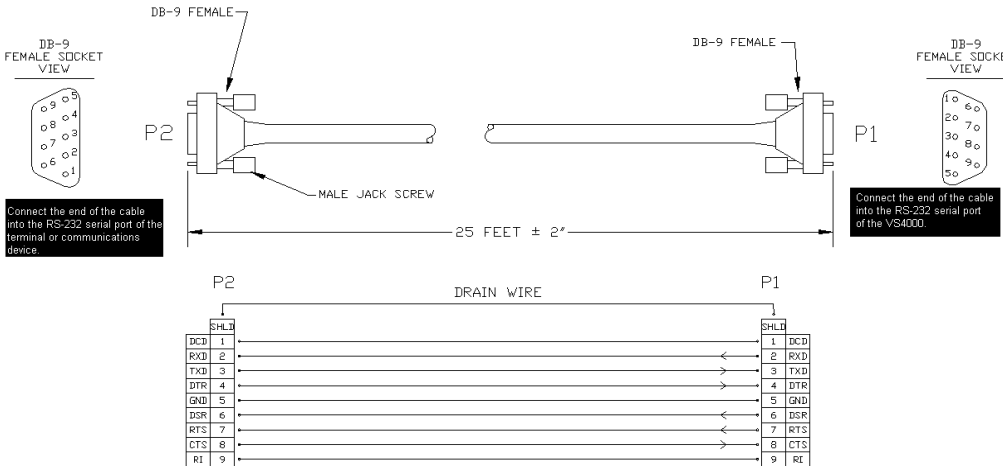

Figure 2-2. RS-232 Cable for VS4000

Quad BRI Network Interface Module

The following paragraphs provide technical information about the Quad BRI network interface module available with the ViewStation EX, ViewStation FX, and VS4000 systems.

If you do not connect the system to an internal telephone system (PBX), you must use a network termination (NT-1) device between the Quad BRI and the ISDN connection at the wall outlet.

Note

Outside the United States or Canada, service providers or public telephone utilities generally provide the NT-1 device.

Indicators on the Quad BRI Network Interface Module

Table 2-13 shows the indicator lamp (LED) activity on the Quad BRI network interface module.

Table 2-13. Quad BRI Indicator Lamps

Indication	Meaning
Green LED	Off = no connection to the switch, or no clock. On = clock is synchronized with the switch.
Yellow LED	Off = in reset mode, booting On = active
Both LEDs on	Normal operation

Note

The indicators do not show whether the SPIDs, switch type, and ISDN numbers have been correctly entered into the endpoint equipment.

Quad BRI Cabling

The Quad BRI network interface module connects to the endpoint using a cable with one keyed RJ-45 connector and one standard RJ-45 connector. Figure 2-3 shows this cable. Because it uses a non-standard connector, Polycom Inc. does not support cables of this type that are fabricated by other vendors.

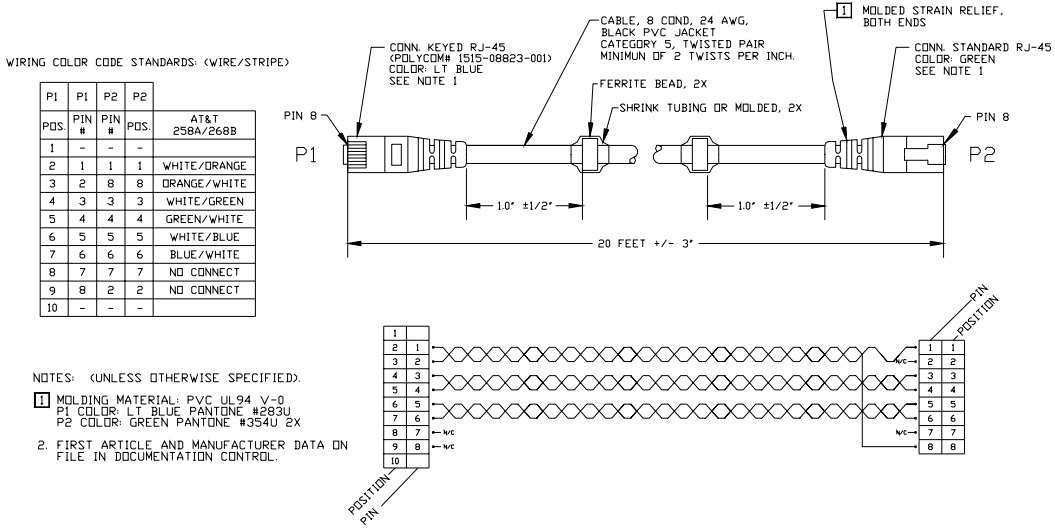

Figure 2-3. Keyed RJ-45 Cable, System to Network Interface Module

Standard RJ-45 to RJ-45 cables connect the Quad BRI to the network. Figure 2-4 shows this type of cable.

WIRING COLOR CODE STANDARDS: (WIRE/STRIPE)

P1	P2	
PIN #	PIN #	AT&T 258A/260B
1	1	WHITE/ORANGE
2	2	ORANGE/WHITE
3	3	WHITE/GREEN
4	4	BLUE/WHITE
5	5	WHITE/BLUE
6	6	GREEN/WHITE
7	7	WHITE/BROWN
8	8	BROWN/WHITE

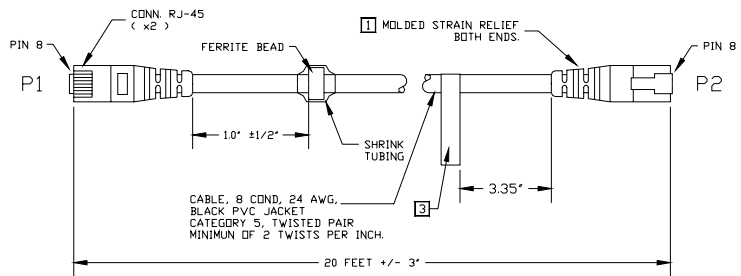

Figure 2-4. Standard RJ-45 Cable, Network Interface Module to Network

NT-1 Information

Following are sample NT-1 settings. For more detailed diagnostic information, see the manual that was shipped with your particular NT-1 device.

Table 2-14. Sample NT-1 Settings

Make and model	Switch	Indicator
ADTRAN NT-1 ACE		Ready = ON Error = OFF Power = ON
Motorola NT1D	1 = ON 2 = ON 3 = ON 4 = ON	SC = ON ACT = ON LB = OFF LP = ON RP = OFF RPR = OFF
Alpha Telecom (AT1) UT620F	1 = ON 2 = ON 3 = OFF 4 = ON	Power = ON ST&U = OFF Back = OFF

ISDN Switches

Depending on the type of ISDN lines you are using, your service provider may assign zero, one, or two SPIDs per line. Refer to Table 2-15 below.

Table 2-15. ISDN Switch Types and SPID Allocations

Switch Type	SPIDs Allocated
AT&T 5ESS Custom	None
AT&T 5ESS NI-1	1 per B-channel
NT DMS-100 NI-1	1 per B-channel
NI-2	1 per device
Siemens EWSD NI-1	1 per B-channel
Siemens EWSD NI-2	1 per device
International (outside United States or Canada)	None

Automatic Quad BRI Software Update

The Quad BRI is expected to have a software version at least as recent as that of the system to which it is connected. If, upon reboot, the system detects an older software version on the Quad BRI, it automatically updates the Quad BRI software. The download is accompanied by an explanatory message.

Caution

Do not turn off your system during the download process.

PRI Network Interface Module for ViewStation FX and VS4000

The following paragraphs provide technical information about the T1 and E1 PRI network interface modules available with the ViewStation FX and VS4000. This network interface module is not available with the ViewStation EX.

Table 2-16. PRI T1 and E1 Network Interface Modules

Parameter	PRI T1	PRI E1
Areas where used	North America, Japan, Hong Kong, Taiwan	Europe, other areas where T1 is not used
B channels	23	30
D channels	1	1
Total data capacity	1472 Mbps (23 x 64 Kbps)	1920 Mbps (30 x 64 Kbps)
Power source	VS4000/ViewStation FX, via peripheral cable External power supply available (required if not using external CSU)	VS4000/ViewStation FX, via peripheral cable External power supply available
Clock source	Network	Network
Keep-alive signal	Yes	No
Switch protocol	AT&T 5ESS AT&T 4ESS Nortel DMS NI-2	NET5/CTR4
Line signalling	ESF/B8ZS	CRC4/HDB3 HDB3
H0 and other higher-bandwidth channels	Not supported	

Table 2-16. PRI T1 and E1 Network Interface Modules (Continued)

Parameter	PRI T1	PRI E1
Non-Facility Associated Signaling (NFAS)	Not supported	
Special services (Caller ID, call blocking, etc.)	Not supported	

Indicators on the PRI Network Interface Module

The tables below describe the expected behavior of the indicator lamps on the PRI network interface module. On the network side, the expected behavior depends on whether it is a T1 module or an E1 module.

Table 2-17. PRI Network Side Indicator Lamps

Indication	PRI T1	PRI E1
Red LED blinking	Not connected to the network, or no power to the upstream equipment	
Red LED on	Connected to the network, but no clock sync	
Yellow LED blinking		Receiving clock and frame sync; receiving RAI from the network with CRC errors
Yellow LED on	Receiving clock and frame sync, waiting for a timer to elapse	Receiving clock and frame sync; receiving Remote Alarm Indication (RAI) from the network with no Cyclic Redundancy Check (CRC) errors
Red and yellow LEDs on		Receiving clock sync; receiving AIS Alarm Indication Signal (unframed all-ones)
Green LED on	Synchronized with the network and ready to use	

Indicator lamps on the peripheral side of the PRI network interface module have the same meanings for both the T1 and E1 models.

Table 2-18. PRI Peripheral Side Indicator Lamps

Indication	Meaning
Amber LED on	The PRI network interface module is in boot mode. ^a
Amber and green LEDs on	New software is being burned into flash.
Green LED on	The PRI network interface module is fully booted. ^b

a. If this LED stays on for more than a minute, new microcode is being uploaded from the system to DRAM.

b. If the PRI network interface module is connected to an external power source, the green LED turns on after several seconds, even if the peripheral link cable is not connected.

PRI Cabling

The peripheral side of the PRI network interface module connects to the endpoint using a cable with keyed RJ-45 connectors. Figure 2-5 shows this cable. Because it uses a non-standard connector, Polycom Inc. does not support cables of this type that are fabricated by other vendors.

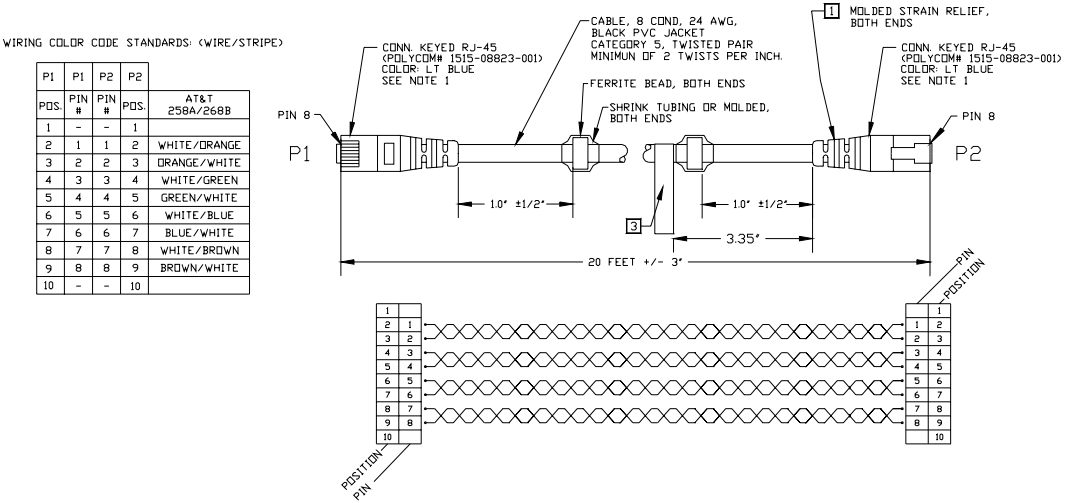

Figure 2-5. Keyed RJ-45 Cable, System to Network Interface Module

A standard RJ-45 to RJ-45 cables connects the PRI to the network. This is the same cable used by the Quad BRI network interface. Figure 2-6 shows this type of cable.

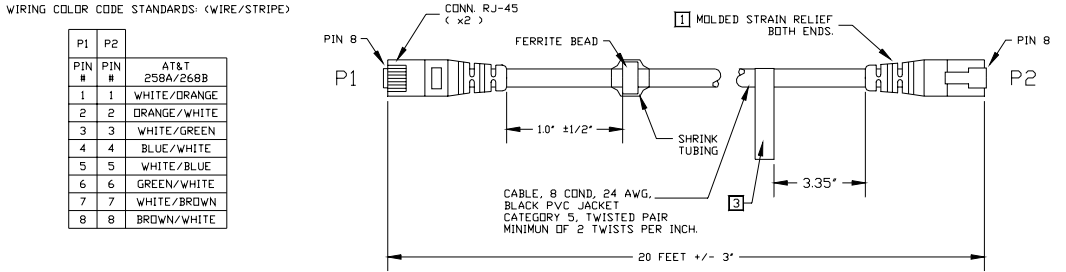

Figure 2-6. Standard RJ-45 Cable, Network Interface Module to Network

Channel Selection

For outgoing calls, the system uses the lowest-numbered available channel (1-23 for a PRI T1 and 1-30 for a PRI E1). If an additional channel is needed, the system chooses the next higher-numbered channel. For example, if channels 1 through 7 are unavailable, but 8 is available, the system uses channel 8 to place an outgoing call. If an additional channel is needed, the system will use the next available active channel in the range (which could be 9, and so on).

For incoming calls, the system uses the highest numbered channel that is available. If another channel is needed, the next lower channel number is used.

PRI E1 Channel Information

The **PRI Status** screen for E1 shows 30 channels. However, E1 trunk lines have 32 timeslots, numbered 0 - 31. Timeslot 0 is used for framing, and timeslot 16 is used for call signaling (the D channel). The remaining 30 timeslots are used as bearer (data) channels.

In call signaling between Polycom equipment and the switch, these channels are numbered 1-15, 17-31. But the PRI Status screen numbers these channels in the range 1-30. On the PRI Status screen, channels 1-15 control the status of timeslots 1-15, and channels 16-30 control the status of timeslots 17-31.

Dedicated Full PRI T1 or E1 Line

All channels should be active for a full T1 or E1 line dedicated to your ViewStation FX or VS4000.

V.35/RS-449/RS-530 Network Interface Module

The following paragraphs provide technical information about the V.35/RS-449/RS-530 network interface module available with the ViewStation EX, ViewStation FX, and VS4000.

The system's V.35/RS-449/RS-530 network interface module is not interchangeable with the previous V.35 network interface module. The new module uses HD-44F connectors for ports 1 and 2, and uses a keyed RJ-45 connector for the serial link to the back panel of the ViewStation FX or VS4000. The cable used with the V.35/RS-449/RS-530 network interface module is the same as is used for the PRI network interface module. It is shown in Figure 2-5. An HD-44M to DB-25F adapter cable is available to connect existing ViewStation DB-25 interface module V.35 network cables.

"Common speeds" are divisible by both 56 and 64. The V.35/RS-449/RS-530 network interface module supports the following common speeds:

- 448 Kbps
- 896 Kbps
- 1344 Kbps (E1 only)

Indicators on the V.35/RS-449/RS-530 Network Interface Module

The following tables describe the behavior of the indicator lamps on the V.35/RS-449/RS-530 network interface module.

Table 2-19. V.35/RS-449/RS-530 Peripheral Side Indicators

Indication	Meaning
Amber LED and green LED flash once	Power-up test
Amber LED off	No communication between endpoint and network interface module
Amber LED on	Communication established between endpoint and network interface module
Amber LED and green LED on	Communication established with network

Table 2-20. V.35/RS-449/RS-530 Network Side Indicator Lamps

Indication	Meaning
Amber LED on	Network interface module is connected to the network and receiving a clock signal
Green LED on	System is in a call

V.35/RS-449/RS-530 Cabling

This section provides cable drawings and pinouts for the three cables that you can use with the V.35/RS-449/RS-530 network interface module. All are common to the ViewStation EX, ViewStation FX, and VS4000.

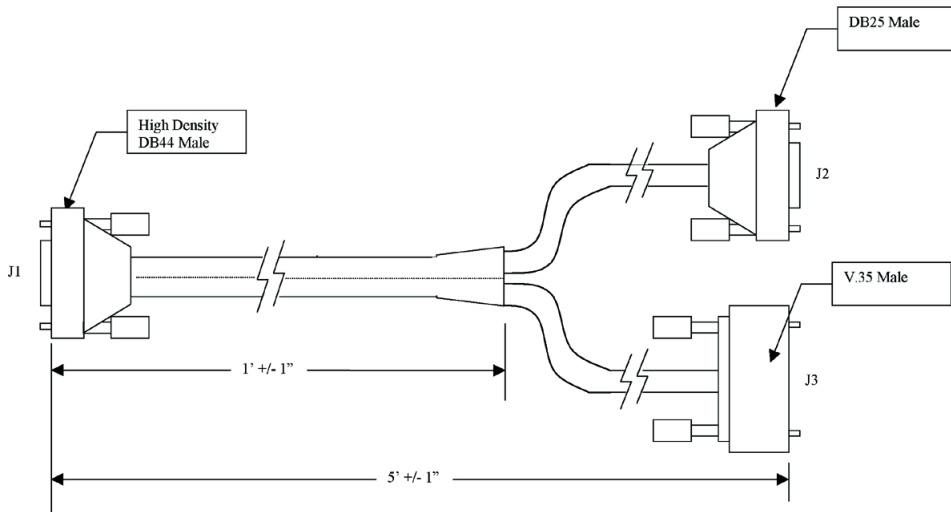

Figure 2-7. HD-44M to RS-366/V.35 "Y" Cable Diagram

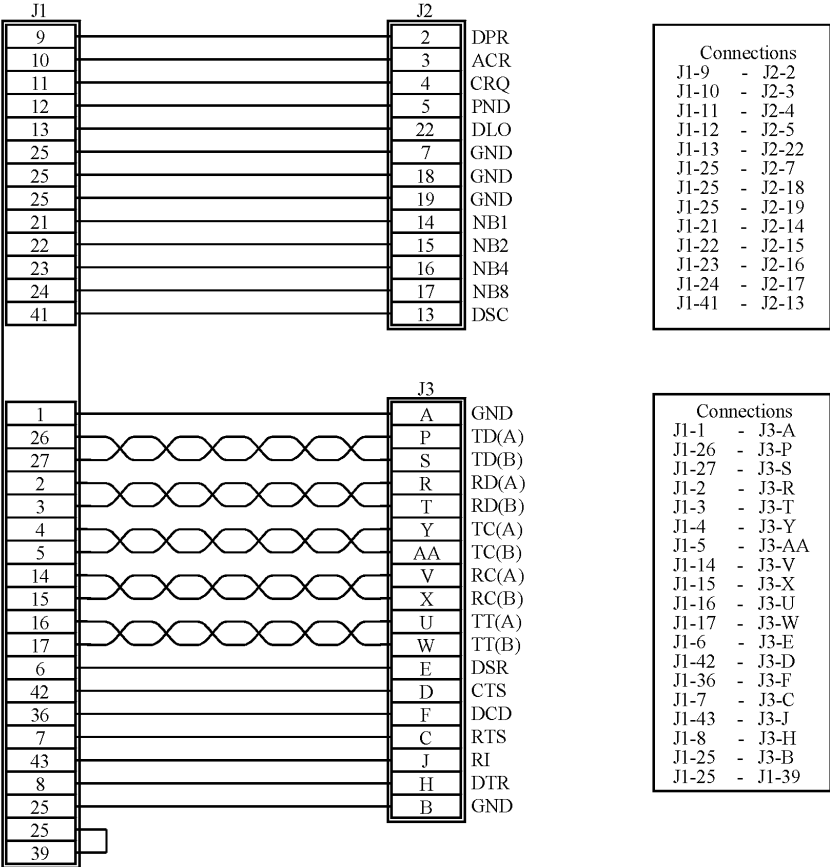

Figure 2-8. Pinout to the HD-44M to RS-366/V.35 "Y" Cable

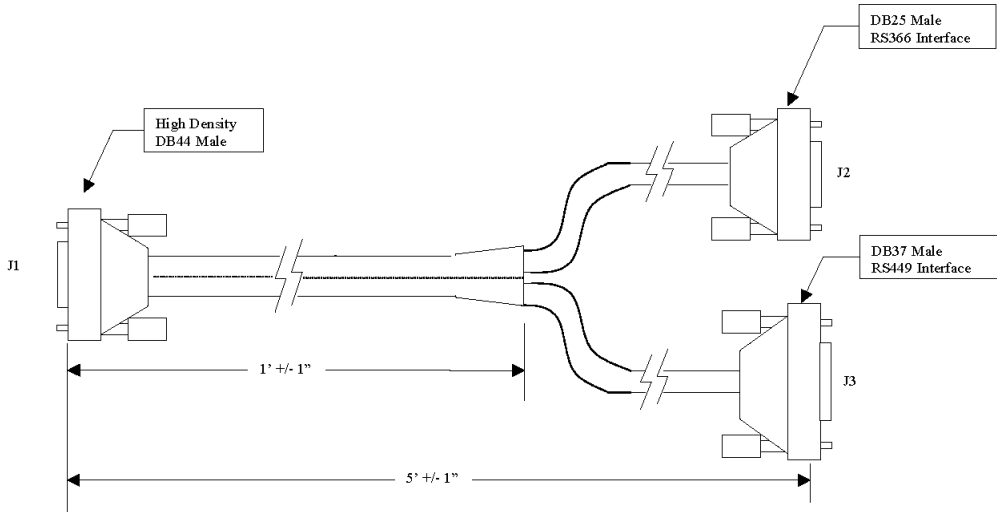

Figure 2-9. HD-44M to RS-449/RS-422 "Y" Cable Diagram

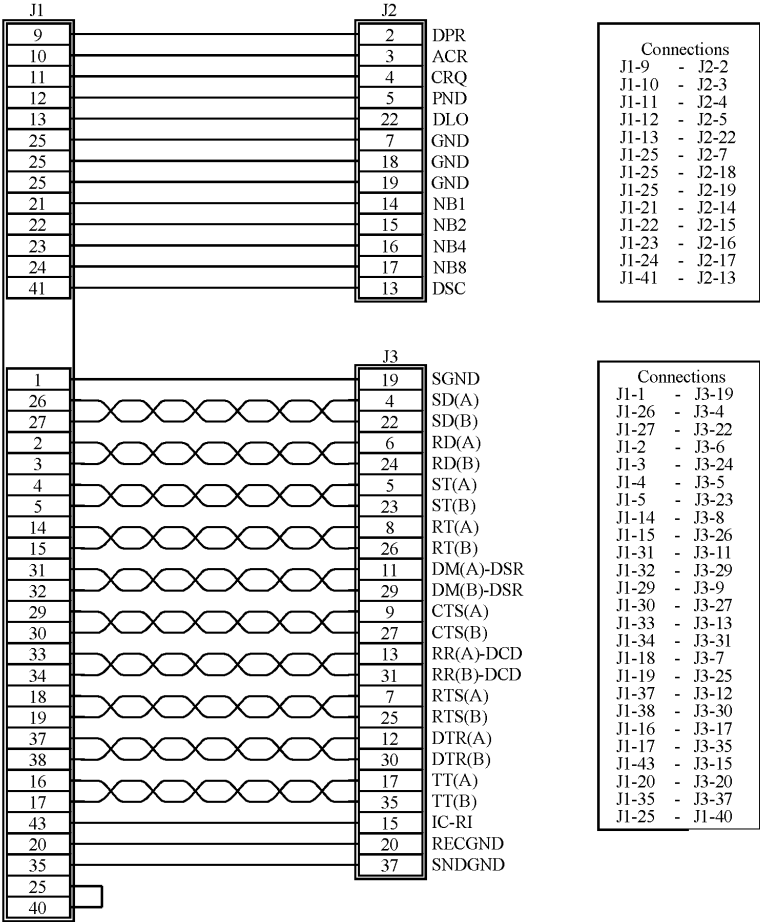

Figure 2-10. Pinout to the HD-44M to RS-449/RS-422 "Y" Cable

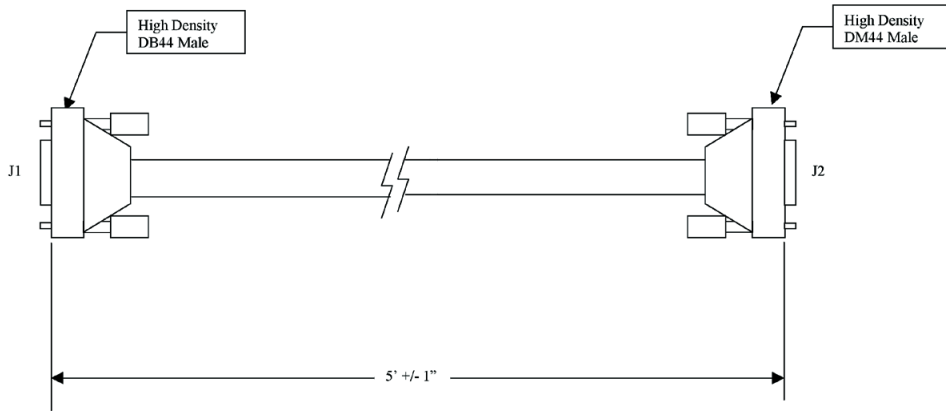

Figure 2-11. Ascend HD-44M to HD-44M Cable Diagram

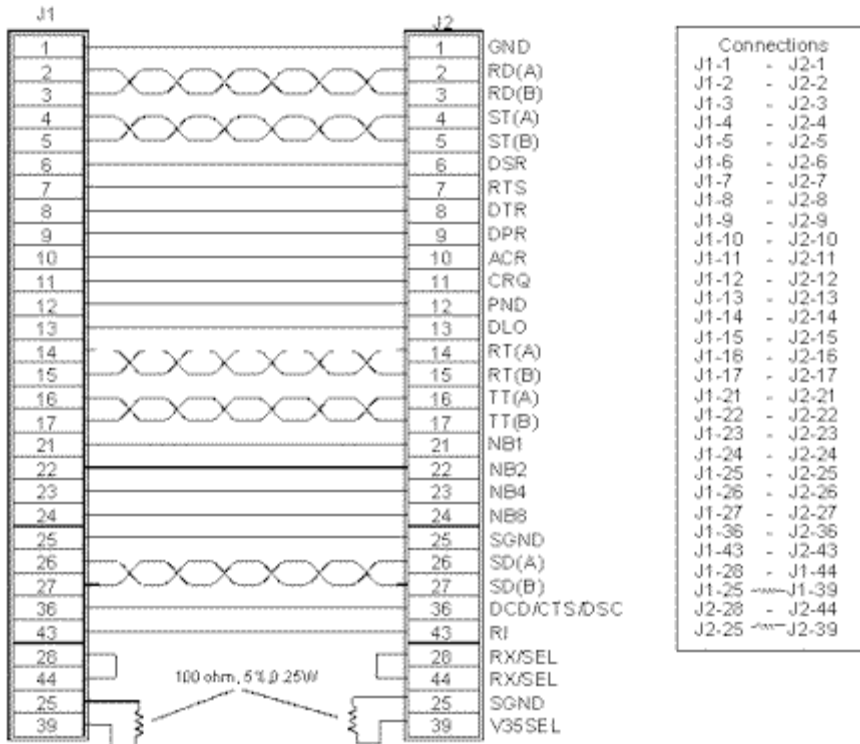

Figure 2-12. Pinout for the Ascend HD-44M to HD-44M Cable

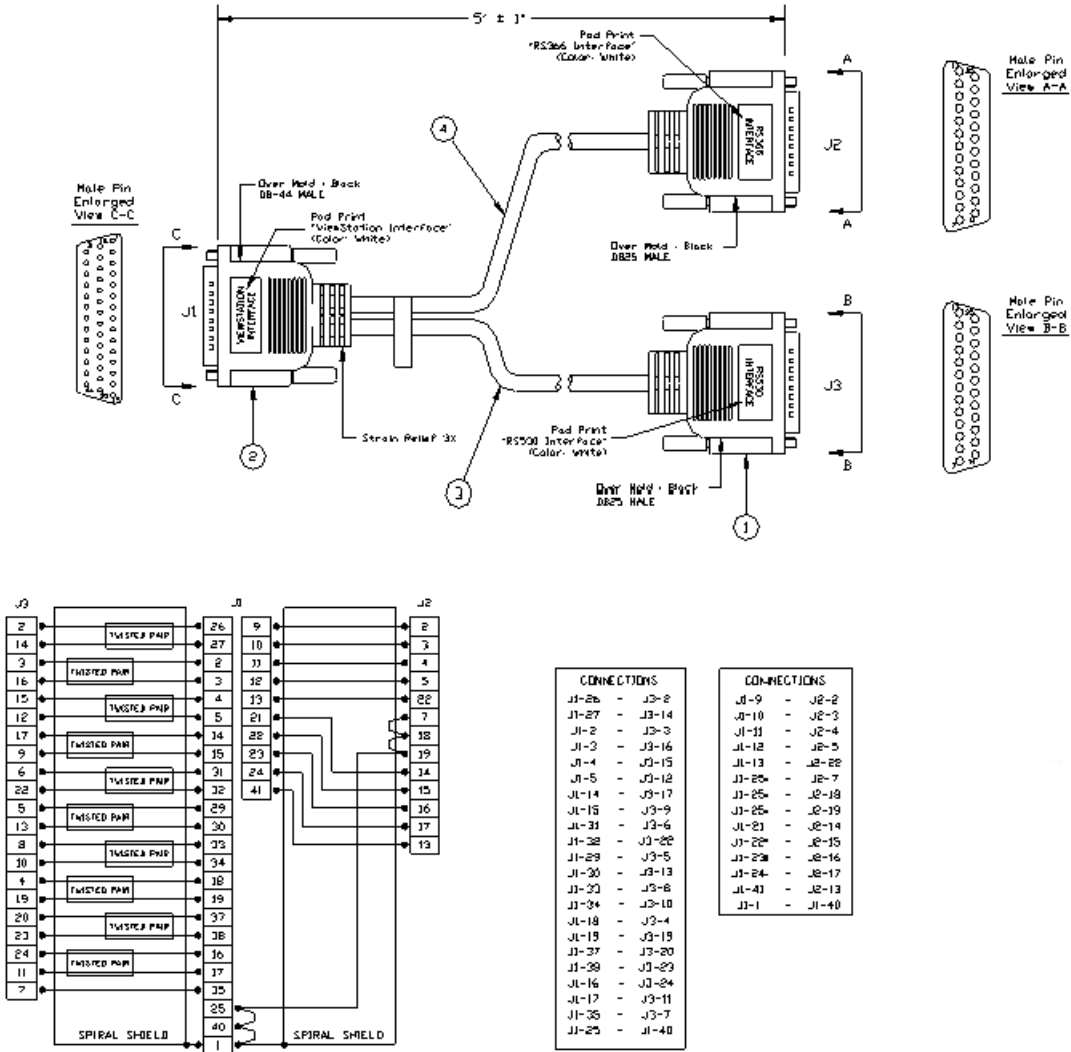

Figure 2-13. RS-530 Cable Diagram and Pinout

Serial Interface Control Signals

If you need to customize your V.35/RS-449/RS-530 interface, use the signal information in Table 2-21 below in addition to the information provided by your network equipment vendor.

Table 2-21. Serial Interface Control Signals

Signal (Pin)	In/Out	Description	Configuration Option
ST (TC/TT)	OUT	Send Timing (clock)	Normal: falling edge sends data Inverted: rising edge sends data
RT (RC)	IN	Receive Timing (clock)	Normal: rising edge receives data Inverted: falling edge receives data
RTS (RTS)	OUT	Request To Send	Normal: high is logic 1 Inverted: low is logic 1
DCD (DCD)	IN	Data Carrier Detect	Normal: high is logic 1 Inverted: low is logic 1 Filter: allow DCD to drop for 60 seconds before changing call state
CTS (CTS)	IN	Clear To Send	Normal: high is logic 1 Inverted: low is logic 1
DTR (DTR)	OUT	Data Terminal Ready	Normal: high is logic 1 Inverted: low is logic 1 On: signal remains high ^a
DSR (DSR)	IN	Data Set Ready	Normal: high is logic 1 Inverted: low is logic 1 Answer: Use DSR as a Ring-In indication ^b

a. If set to ON, inverted is not an option.

b. DSR is not used as a ring-in indication if it is set to ANSWER in the **V.35 Advanced Setup** screen.

State Machine

The V.35/RS-449/RS-530 state machine controls how the V.35/RS-449/RS-530 interface signals handshake with the network interface equipment while the call is being established. The following tables describe the machine states.

Table 2-22. Dial-Out State Machine

State	ViewStation or VS4000 Signals	Network Signals
1	Initial State: DTR = 0 ^a RTS = 0 ^b CRQ = 0 USER INITIATES CALL	Initial State: RI = 0 DLO = 0 ACR = 0 DSR = 0
2	DTR = 1 ^a	
3	Wait 10 ms	
4	CRQ = 1	
5		PND = 1
6	Set Digit (NB1,NB2,NB3,NB4)	
7	DPR = 1	
8		PND = 0
9	DPR = 0	
10	If not last digit, go to state 4; else continue	
11		Call connects on network
12		DSR = 1 AND/OR DCD = 1 (AND/OR DSR = 1 ^c)
13	RTS = 1 ^b	
14	DATA FLOW STARTS	DATA FLOW STARTS
	User Hang-up	Far end hang-up

Table 2-22. Dial-Out State Machine (Continued)

State	ViewStation or VS4000 Signals	Network Signals
15	RTS = 0 ^b DTR = 0 ^a CRQ = 0 All signals go low if Far End or User hang up is detected	DSR = 1 to 0, OR DCD = 1 to 0 A falling edge on DSR or DCD are interpreted by the ViewStation FX or VS4000 as a hang-up
16	IDLE DTR = 0 ^a RTS = 0 ^b CRQ = 0	IDLE RI = 0 DLO = 0 ACR = 0 DSR = 0

a. DTR does not act as shown but remains high if DTR is set to ON in the **V.35 Advanced Setup** screen.

b. RTS does not act as shown but acts as a resync pulse if Security/Crypto-Resync is set to ON.

c. DSR is used as a ring-in indicate if DSR is set to ANSWER in the **V.35 Advanced Setup** screen.

Table 2-23. Inbound Call State Machine

State	ViewStation FX or VS4000 Signals	Network Signals
1	Initial State: DTR = 0 ^a RTS = 0 ^b CRQ = 0	Initial State: RI = 0 DLO = 0 ACR = 0 DSR = 0
		REMOTE USER INITIATES CALL
2		RI= 0 to 1, or DCD= 0 to 1, or DSR= 0 to 1 ^c
3	Notify user of ring-in ^d	
4	System accepts call	

Table 2-23. Inbound Call State Machine (Continued)

State	ViewStation FX or VS4000 Signals	Network Signals
5	DTR = 1	
6	RTS = 1 ^b	
7	Wait for DSR high	
8		DSR = 1 AND/OR DCD = 1 (AND/OR DSR = 1 ^c)
9	Go to connected state	
10	DATA FLOW STARTS	DATA FLOW STARTS
11	User Hang-up	Far End Hang-up
12	RTS = 0 ^b DTR = 0 ^a CRQ = 0 All signals go low if Far End or User hang up is detected	DSR= 1 to 0, OR DCD= 1 to 0 OR CTS= 1 to 0 A falling edge on DSR or DCD or CTS is interpreted by the FX/VS4000 as a hang-up ^e
13	IDLE DTR = 0 ^a RTS = 0 ^b CRQ = 0	IDLE RI = 0 DLO = 0 ACR = 0 DSR = 0

a. DTR does not act as shown but remains high if DTR is set to ON in the **V.35 Advanced Setup** screen.

b. RTS does not act as shown but acts as a resync pulse if Security/Crypto Resync is set to ON.

c. DSR is used as a ring-in indicate if DSR is set to ANSWER in the **V.35 Advanced Setup** screen.

d. If RS-366 Dialing is not enabled, auto answer must be enabled. If auto answer is not enabled, ring-in will be ignored when in non-dialed mode.

e. If DCD filter is set to ON in the **V.35 Advanced Setup** screen, the system will not react to a low DCD until DCD has been low for 60 seconds.

Table 2-24. Non-Dialed User-Initiated Call State Machine

State	ViewStation FX or VS4000 Signals	Network Signals
1	Initial State: DTR = 0 ^a RTS = 0 ^b CRQ = 0	Initial State: RI = 0 DLO = 0 ACR = 0 DSR = 0
	USER INITIATES CALL	
2	DTR = 1 ^a	
3	RTS = 1 ^b	
4		DCD = 0 to 1
5	DATA FLOW STARTS	DATA FLOW STARTS
	User Hang-up	Far end hang-up
6	RTS = 0 ^b DTR = 0 ^a CRQ = 0 All signals go low if far end or User hang up is detected	DSR= 1 to 0, OR DCD= 1 to 0 A falling edge on DSR or DCD is interpreted by the FX/ VS4000 as a hang-up ^c
7	IDLE DTR = 0 ^a RTS = 0 ^b CRQ = 0	IDLE RI = 0 DLO = 0 ACR = 0 DSR = 0

a. DTR does not act as shown but remains high if DTR is set to ON in the **V.35 Advanced Setup** screen.

b. RTS does not act as shown but acts as a resync pulse if Security/Crypto Resync is set to ON.

c. If DCD filter is set to ON in the **V.35 Advanced Setup** screen, the system does not react to a low DCD until DCD has been low for 60 seconds.

Table 2-25. Non-dialed Network-Initiated Call State Machine

State	ViewStation FX or VS4000 Signals	Network Signals
1	Initial State: DTR = 0 ^a RTS = 0 ^b CRQ = 0	Initial State: RI = 0 DLO = 0 ACR = 0 DSR = 0
		USER INITIATES CALL
2		DCD = 0 to 1
3	DTR = 1 ^a	
4	RTS = 1 ^b	
5	DATA FLOW STARTS	DATA FLOW STARTS
	User hang-up	Far end hang-up
6	RTS = 0 ^b DTR = 0 ^a CRQ = 0 All signals go low if far end or User hang up is detected	DSR = 1 to 0, or DCD = 1 to 0 A falling edge on DSR or DCD is interpreted by the FX/ VS4000 as a hang-up DCD = 0 ^c
7	IDLE DTR = 0 ^a RTS = 0 ^b CRQ = 0	IDLE RI = 0 DLO = 0 ACR = 0 DSR = 0

a. DTR does not act as shown but remains high if DTR is set to ON in the **V.35 Advanced Setup** screen.

b. RTS does not act as shown but acts as a resync pulse if Security/Crypto Resync is set to ON.

c. If DCD filter is set to ON in the **V.35 Advanced Setup** screen, the system does not react to a low DCD until DCD has been low for 60 seconds.

Crypto Resync

If a cryptographic encoder/decoder is connected between the system and the network, it may require a resynchronization signal from the system. This is a signal indicating that the system has lost video synchronization due to a network problem and requires that the cryptographic encoder/decoder resync with the equipment at the other end of the connection.

To use this feature, select **System Info > Admin Setup > Security**. When you select the **Crypto Resync** option, the **Crypto Resync Pulse** screen appears.

On this screen you can enable crypto resync, set the time between pulses (in seconds), and set the pulse width (in milliseconds).

If the system loses H.320 synchronization while in a call, it sends the resynchronization pulses at the specified rate until H.320 regains synchronization.

The resync pulse is output on the RTS signal. If this feature is enabled, the RTS signal no longer functions as the Ready-To-Send signal.

Most installations that use encryption equipment require a custom cable. The cable should route the RTS signal from the system to the appropriate resync input on the encryption equipment. The encryption equipment can get its RTS input from the videoconferencing system's DTR output or by tying this input high. In this non-dialed mode, the DTR output and RTS output act alike.

Other Elements of a Typical Deployment

A typical deployment includes some of the following Polycom equipment and software in addition to videoconferencing endpoints:

- MGC Manager™
- Global Management System™
- WebCommander™
- PathNavigator™

For more information, please refer to the documentation supplied with the products deployed within your organization, or see www.polycom.com.

3

Before You Deploy

This chapter provides a summary of the deployment process, and describes what you must do to prepare for installation.

This chapter covers the following topics.

Topic	Page
Predeployment Overview	48
Video Network Security	49
Best Practices	50
Predeployment Planning	51
Developing the Dial Plan	55
ISDN Requirements	63
Site Considerations	72
Predeployment Worksheet	74

Predeployment Overview

The diagram below gives an overview of the tasks involved in predeployment planning.

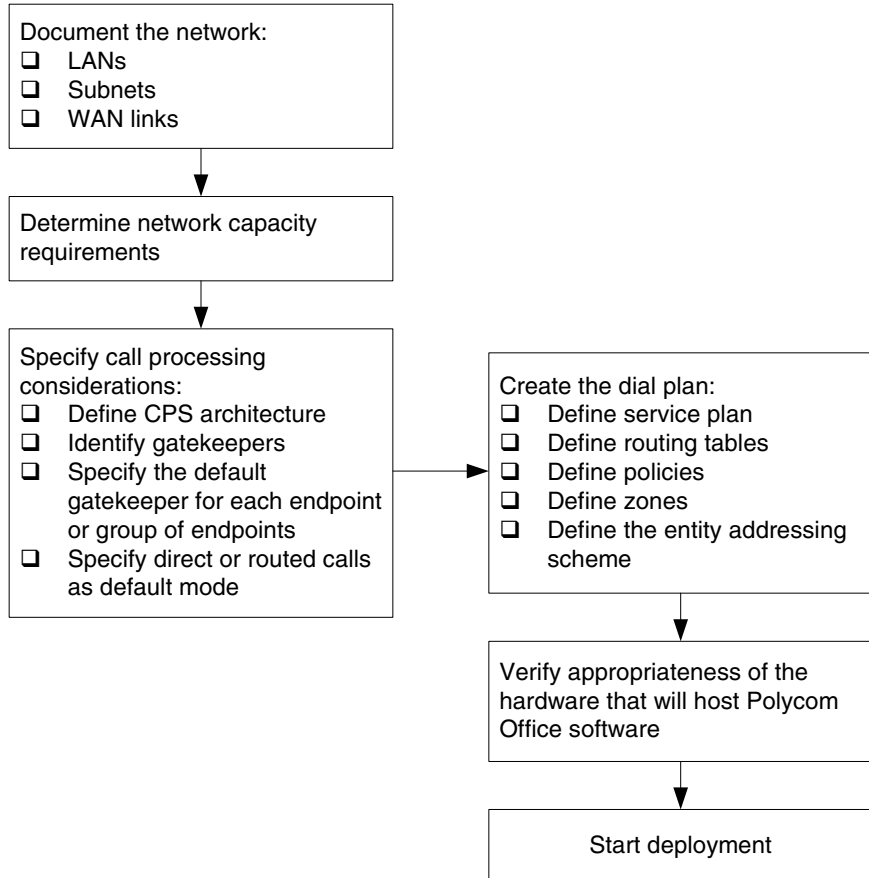

Figure 3-1. The Predeployment Process

Video Network Security

Polycom recommends the following general precautions to keep your video network secure:

- Deploy IP endpoints behind a firewall.
- If your deployment seldom requires centralized management capabilities, disable all endpoints' remote management capabilities.
- If your deployment does not ever require centralized management capabilities, consider an ISDN-only deployment.

For detailed discussions of how to secure specific models of videoconferencing equipment, please refer to the documents available at Polycom's Security Center, <http://www.polycom.com/securitycenter>.

Best Practices

Polycom recommends the following as best practices when deploying Polycom IP voice and video applications.

- ❑ **Consider latency, jitter, and packet loss.** All are obstacles to high quality audio and video. Table 3-1 below recommends maximum values for these parameters.

Table 3-1. Latency, Jitter, and Packet Loss

Parameter	Maximum recommended value
Latency	less than 150 ms one way; 300 ms end to end
Jitter	50 ms or less
Packet loss	1% or less

- ❑ **Consider system requirements.** Be sure to meet the minimum server hardware requirements of all software-based products.
- ❑ **Consider network requirements.** Building an end-to-end H.323 video network requires an infrastructure based on layer 2 and layer 3 switches and routers.

When planning the deployment of multimedia communication applications, ensure that switches and routers can handle more than one queue and are enabled to process applications with different requirements relating to latency, jitter, and loss characteristics.

- ❑ **Set IP precedence appropriately (if applicable).** Some Polycom systems can set the precedence level for use in Quality of Service (QoS) enabled networks.
- ❑ **Determine bandwidth requirements.** Consider the total amount of bandwidth associated with video sessions prior to deployment. It is recommended that all H.323 video endpoints, CPSs, gateways, and MCUs be connected to a dedicated 10/100 switched-Ethernet port.

Notes

Older Polycom ViewStation systems and the RADVision MCUs and gateways both support 10 Mbps half duplex only.

There are known issues with some older Cisco Catalyst 10/100 switches and video endpoints negotiating half/full duplex. If the negotiation fails, the endpoint will still function, but the system will experience video freezing every 3 to 5 seconds.

Predeployment Planning

The main factors to consider in planning the deployment are:

- LAN/WAN considerations — document the LANs, subnets, and WAN links involved in the deployment.
- Capacity planning — assess the bandwidth requirements for the deployment.
- Call processing considerations — define call processing architecture and identify gatekeepers, define registration policy and call policy.
- Dial plan — define details of services, routing, policies, zones, and addressing.
- Server requirements — verify that all management software will be installed on suitable equipment.

LAN/WAN Considerations

You will need to develop a network topology checklist that includes the following information:

- ❑ **List of Networks:** To take advantage of least cost routing and alternate routing, you must define the topology of the Local area networks (LANs) that each gatekeeper serves, as well as the LANs that are logically connected to these but served by other gatekeepers. This allows the gatekeeper to determine how IP traffic is routed from one endpoint to the next. PathNavigator uses the network topology to determine when resources are unavailable so that an alternate (ISDN) path can be determined.
- ❑ **Subnets within each network and subnet IP address:** A network address is the equivalent of a subnet. You will need to define all subnet addresses within your LAN. If this information is not available to the gatekeeper, calls may be rejected because no route can be determined.
- ❑ **WAN links:** These are logical connections from one LAN to another LAN within the WAN cloud, or logical connections from one network to another network outside of the organization. The two types of WAN links are the dedicated WAN link, which is a logical connection via a dedicated link, leased line, frame relay or through an ATM network; and the WAN link to other networks through a VPN tunnel, which connects one network to another through a secure connection over the Internet.
- ❑ **Network Diagram** describing how networks are connected and bandwidth capacity on each WAN link.

Each gatekeeper will need information about its neighbor gatekeepers to be able to communicate with them. Neighbor gatekeepers manage other H.323 zones within an organization and allow the network's workload to be distributed across logical boundaries within the organization. This enables more efficient use of the network by limiting communication between zones (across WAN links). When a call originates with one gatekeeper's zone and that zone's gatekeeper is unable to resolve the dialed address, it will be forwarded to the neighbor gatekeepers for resolution. The port used for gatekeeper-to-gatekeeper communication is usually 1719.

Capacity Planning

H.323 traffic uses more bandwidth than the selected call quality or H.320 equivalent. Polycom recommends that you allow 20% overhead for the H.323 signaling traffic. ISDN networks do not include signaling in the payload calculations, but in TCP/IP networks all signaling must also be accounted for. For example, a 384-Kbps video call would require approximately $384 \text{ Kbps} + 20\% = 460 \text{ Kbps}$ of bandwidth on a TCP/IP network. These figures assume a full-duplex network.

If H.323 traffic starts out on a half-duplex network segment, it will require twice the bandwidth indicated by the bandwidth calculations described above. It will, however, take advantage of full-duplex segments as soon as it reaches them. For full-duplex segments, the calculations above remain valid. WAN segments (T1, Frame Relay, ATM) are typically full-duplex.

The following equations will help in determining the bandwidth required for H.323 traffic across various network segments:

- Full-duplex Ethernet = (Call Speed + 20%) x 1
- Half-duplex Ethernet = (Call Speed + 20%) x 2
- Wide Area Network = (Call Speed + 20%) x 1
- ATM (Using LANE) = (Call Speed + 35%) x 1

The table below provides a comparison between H.320 and H.323 point-to-point calls.

Table 3-2. Bandwidth Requirements

Call Quality (Speed)	Bandwidth Required over ISDN (H.320)	Bandwidth Required over IP (H.323)
128 Kbps	1 Basic Rate ISDN (BRI) line	153 Kbps
256 Kbps	2 BRI lines	307 Kbps
384 Kbps	3 BRI lines	460 Kbps
512 Kbps	4 BRI lines	614 Kbps
768 Kbps	Fractional T1 or full Primary Rate ISDN (PRI) line	922 Kbps

Table 3-2. Bandwidth Requirements

1.5 Mbps	1 PRI line	1.843 Mbps
2.0 Mbps	Multiple ^a PRI lines or E1 line (Europe)	2.4 Mbps

a. Requires a third-party inverse multiplexer. Inverse multiplexers provide inverse multiplexing to transmit a single high-speed data channel over one or many T1 (PRI) or E1 links.

Keep in mind that the examples given here discuss only a single point-to-point call. Your capacity planning calculations must take into account the total number of calls that you expect the network to handle at one time, including multipoint calls. In addition, you will need to factor in the requirements for any other traffic that the network must handle.

For detailed information about capacity planning, please refer to the Polycom white paper, H.323 Bandwidth Considerations, available at www.polycom.com.

Call Processing Considerations

After documenting your network topology, you will need to define:

- Call processing architecture
- Gatekeeper identifier
- Default gatekeeper
- Call routing mode

Defining the call processing architecture is outside the scope of this document. Please refer to the **PathNavigator Deployment Guide** in the Documentation section at www.polycom.com for detailed information on this topic.

Gatekeeper Identifier

You will need to specify the gatekeeper identifier for each gatekeeper being deployed. You must also define the maximum number of endpoints that may be registered to each gatekeeper and the maximum number of calls that each gatekeeper may handle at one time.

Default Gatekeeper

An endpoint may register to a gatekeeper automatically or manually. If endpoint registration is automatic, the registration policy must specify a default gatekeeper — more than one gatekeeper may exist on the network.

The registration policy defines the endpoints that may register to the gatekeeper. It may allow any endpoint to register, or it may restrict registration to specific endpoints or endpoints on specific networks.

Call Routing Mode

The default call mode may be direct or routed. In direct call mode, the gatekeeper allows endpoints to send messages directly to each other — the calls do not need to be routed through the gatekeeper. If direct call mode is used, gatekeeper functionality (such as simplified dialing, Conference on Demand, and alternate routing) is not available, because the call bypasses the gatekeeper.

Developing the Dial Plan

The final element of the predeployment preparations is the dial plan.

The dial plan defines how you set numeric aliases and service prefixes. Numeric aliases look like telephone numbers. They allow people to dial a short string of numbers like a telephone extension or local telephone number instead of entering a full IP address.

Service prefixes are short numeric strings that identify the services being requested, such as call speed and zone.

An H.323 dial plan allows you to associate a numeric alias to the network address of each H.323 entity. This is the calling plan that you develop for H.323 deployments.

In large deployments, the dial plan also helps to manage resources by segmenting user populations.

The dial plan defines the following elements of the deployment:

- Services — these include system services, gateway and MCU services.
- Routing and policies — these include the default group policy and least-cost routing tables.
- Network topology — includes private numbering plans (E.164 provisioning) or a public dialing plan (ISDN alias assignment).
- Neighbor gatekeepers — these are gatekeepers that manage other H.323 zones within an organization.
- Addressing — specifies the requirements for assigning zone and service prefixes and endpoint addresses.

Before you design a dial plan, you should document:

- Current telephone number dialing patterns
- Planned router locations
- Traffic routing requirements

Because no standard protocol defines the dynamic routing of E.164 addresses, H.323 dial plans must be configured statically and managed on gateway and gatekeeper platforms.

To reduce the complexity of the configuration, confine H.323 addresses to one portion of the dial plan.

A well-designed dial plan distributes the dial plan logic among the gateways and gatekeepers. Try to keep the dial plan logic at the highest component level — for example, allow the gatekeeper to handle routing and fail-over decisions. This allows individual zones to be added or modified without affecting other zones, so the deployment is very scalable.

To assign gateways and gatekeepers:

1. Determine the area that your dial plan covers.
2. Determine what calling area(s) each gateway and gatekeeper will be responsible for.
3. Determine the peak traffic volume, and determine how many gateways will be required to handle anticipated increases in this peak volume.
4. Logically group the gateways into zones to determine how many gatekeepers you need. A zone can have one or many gateways. The number of zones you define depends on the gateways' capacity and traffic.
5. Determine which gatekeeper should administer each zone.

Services

System services are defined within PathNavigator. They include many of the functions that simplify the user's interaction with the Polycom Office. System services only work within a zone.

PathNavigator's gateway and MCU services make it simple for the user to dial out through a gateway or dial into a conference. For these services to be effective, the gateway service information such as call speed, service and zone prefixes, and device capabilities must be registered with PathNavigator.

Gateway and MCU services are defined in both PathNavigator and the MGC platform itself. It is critical that the prefixes are exactly the same in each system.

Administration, Policies, and Routing

Administration Plan

The videoconferencing administration plan allows the system administrator to manage user permissions and network policies. Your plan should define:

- Superusers
- Administrators
- Permissions for groups and for individuals
- Policies such as bandwidth allocation per user

Default Group Policy

A group policy allows you to define dialing properties, services, and bandwidth management parameters for all members of a defined group without having to configure these individually for each user.

The default group is normally all users, and the policy settings for this group are the default group policy. The administrator sets policy, services, and other settings for this and other groups.

Least-Cost Routing

Least-cost routing enables calls that originate inside the organization to be routed in the manner that incurs the lowest expense. In order for least-cost routing to be implemented, the network topology must be defined — the gateways on each network, WAN link capacities, and other factors.

Each gateway has an associated least-cost routing table which is created by the administrator. The table consists of dial string entries (country code, area/city code, etc.) and cost. For calls between networks, the tables are compared to identify the least-cost route for the call. Least-cost routing will not be used if the least-cost route cannot be identified, if the required resources are unavailable, or if bandwidth limitations exist on the WAN link.

If your organization has special rate plans, those should be incorporated into the least-cost routing tables.

Network Topology

You will need the network topology information described in [LAN/WAN Considerations on page 52](#) when you design your dial plan and configure PathNavigator to manage your video network.

If the network is physically changed, you will need to update PathNavigator's network information so that it can manage the video network effectively.

PathNavigator provides the means for you to assign ISDN numbers to endpoints. The way numbers are assigned depends on your network:

- E.164 provisioning** — Choose E.164 provisioning if you are using private numbers.
- ISDN alias assignment** — If you assign ISDN numbers to endpoints, then the ISDN ranges need to be provided to the gatekeeper. These numbers must be coordinated with your local ISDN provider as these numbers cannot be self-populated. Assigning numbers that are not in your domain will result in failed calls when users outside the organization try to access users within the organization with self-populated numbers.
- Automatically assigned numbers** — PathNavigator can automatically assign direct inward dial (DID) numbers or gateway extensions. You cannot automatically assign both types of numbers on the same network.

Neighbor gatekeepers

Neighbor gatekeepers allow for the distribution of the workload across logical boundaries within the organization. This enables more efficient use of the network by limiting communication across WAN links. When a call originates in one gatekeeper's zone and that gatekeeper is unable to resolve the dialed address, it will be forwarded to the neighbor gatekeepers for resolution.

Addressing

The addressing components of an H.323 dial plan are:

- Gatekeeper zone identifiers or prefixes
- Entity addressing
- Terminal aliases (include numeric and alphabetic aliases)
- System Services
- MCU service prefixes
- Gateway service prefixes

Each H.323 entity must have at least one network address (transport address). The network address uniquely identifies the H.323 entity on the network. It is typically a TCP/IP address.

If the entity is a terminal, it may also have one or more alias addresses associated with it.

Zones and Zone Prefixes

A zone is the collection of all terminals, gateways, and MCUs managed by a single gatekeeper. A zone may be independent of network topology, and may include multiple network segments which are connected by routers and other devices.

When using multiple zones (multiple gatekeepers), zone identifiers must be used. Zone identifiers are analogous to area codes.

Specifying local zone prefixes enables the gatekeeper to resolve addresses sent by neighbor gatekeepers. The local zone prefix identifies this gatekeeper. Some gatekeepers do not strip prefixes before the address when sending out a request for address resolution. These addresses cannot be resolved without the local zone prefix. The local zone prefix needs to be removed from the dialed address in order to match the address to a registrant.

Table 3-3. Zone Identifiers and Neighbor Gatekeepers

Prefix	Milpitas gatekeeper	Austin gatekeeper	Atlanta gatekeeper
Local zone prefix	408	512	770
Neighbor gatekeeper 1 prefix	512	408	408
Neighbor gatekeeper 2 prefix	770	770	512

If the local zone prefixes are configured, requests from neighbor gatekeepers with prefixes that match the local zone prefix will be resolved. All other calls will be rejected.

Entity Addressing

An entity must have a network address and may have alias addresses. These are defined as follows:

- Network address:** This address relates to network transport. It is usually a TCP/IP address. This address can either be automatically issues via dynamic host configuration protocol (DHCP), or statically assigned by the administrator from a pool of available addresses.
- Alias address:** This may be a telephone number (private number or public E.164 address) or an H.323 identifier, which is an alphabetic string such as a username, email-like address, or H.323 URL.
- LAN host name:** Any system connected to a LAN must have a LAN host name (netBIOS name) defined. This is sometimes called the computer name.

An alias address may represent a terminal or it may represent a conference. Alias addresses must be unique within a zone. For example, within a zone there may only be one entity that uses the alias 3721005.

Rules for Assigning Prefixes and Numeric Aliases

In assigning prefixes and numeric aliases, it is critically important to observe certain rules:

- MCUs and gateways provide services, so they must have service prefixes assigned to them. Each service must have its own prefix. For example, an MCU or gateway will have a separate service prefix for each call speed that it provides.
- MCU and gateway services work across zones only if used in conjunction with a manually entered zone prefix.
- If the system uses more than one gatekeeper, each gatekeeper must have a zone identifier prefix.
- The numeric aliases for terminals and conferences may begin with the same initial digit(s) as any service prefix or zone identifier prefix. This is because PathNavigator's parsing rule is that aliases are checked first and service prefixes are checked last.
- The numerals used for service prefixes may not start with an existing service prefix. Example: If 9 is selected as your access simplified dialing system service, then you may not create MCU or gateway service prefixes that begin with 9.
- Local zone prefixes are not considered local service prefixes. Therefore, if you have a local zone prefix of 408, you may still use 40 to designate a service.

Service Plans

A service plan assigns numeric prefixes to services on the network. Gatekeepers use service prefixes to route terminal requests to the appropriate provider of services. Services on the network are processed by media processors on the network. Within H.323, media processors are MCUs, gateways, and proxies. A service prefix is analogous to the digit 9 that you must dial to request an outside line from a PBX system; the system's response of connecting you to the requested outside line would be the service in this example.

System Services

System services include the following:

- Conference on demand
- Call forwarding: set forward busy, set forward no answer, and set forward unconditional.
- Access simplified dialing
- Join or leave hunt group

System services only work within a zone. They do not work across zones.

Gateway and MCU services are defined in both PathNavigator and the MGC platform itself. It is critical that the prefixes are exactly the same in each system.

ISDN Requirements

The following paragraphs describe the requirements for ISDN PRI and BRI interfaces.

ISDN PRI

The PRI network interface is available for the ViewStation FX and VS4000.

Note

Polycom ISDN PRI modules include an internal CSU for the PRI interface. The system's internal CSU can be disabled via the Admin Setup.

The PRI T1 needs to be provisioned for the ViewStation FX and VS4000 systems as follows:

Table 3-4. ISDN PRI Requirements

Line settings	ESF/B8ZS (default) Extended Super Frame B8ZS is modem standard for T1/PRI line encoding and framing
Line termination type	CPE (user side) only The required termination is built into the system and most access switches
Supported PRI switch protocols	AT&T 4ESS, AT&T 5ESS, NI-1, NI-2, Siemens, Nortel DMS 100, and Nortel 250 These are standard protocols for North America
Number of channels	23 B-channels dialable at 64 or 56 Kbps, and one D channel Ensure that you have 64 Kbps clear channel service
Number of network interfaces	1 (single PRI)
Line build-out modes	DSU+CSU (0 to -22.5dB attenuation), DSU-only (DSX 0-665 feet) Physical distance is offset by the settings in the user interface
Clocking	Must be derived from the external network or the PBX
Terminal Endpoint ID (TEI)	0-63 This identifies the PRI endpoint; the common default is 0
Numbering	One local directory number per interface (23 channels)
D-channel slot number	24 Included to verify where the D channel is; this is where additional diagnostic information resides
Call-by-call service codes	Values 0-31 service codes for GVPN/PN/UPN network-specific services

The PRI direct from the telephone service provider should support both data and voice for Polycom's voice add-on capability of systems.

Determining Usage

To get the best rate of return from PRI lines, they should be used as much as possible. To do this, look at the data and video traffic as a whole. Establish a reasonable ratio between the total bandwidth required if every device is in use and the number of lines provided. A ratio of 10:1 is fair for general use. If you use a PBX, access switch, or other data communications unit, the total number of lines into your customer premise equipment (CPE) can be allocated by channel to your equipment, according to the bandwidth required at any given time.

PBX Network Configuration

The PBX or other CPE that will be providing the ISDN PRI interface to the system must be able to provide a clock signal.

Other than the clocking requirement, the rest of the ISDN PRI provisioning on the PBX is very similar to what would be requested of an outside ISDN provider.

ISDN BRI

All Polycom ISDN BRI interfaces are S/T-loop. ISDN BRI lines coming direct from a Telco are U-loop, so if your system is not behind a PBX or other private network, you must connect the BRI interface to BRI line(s) through an NT1 device capable of supporting multiple BRI lines.

NT1 Devices that you may order through Polycom:

- Single NT1 (2200-08406-001 or NT1)
- Triple NT1 (2200-08406-003)
- Quad NT1 (2200-08406-004 or NT1-QUAD)

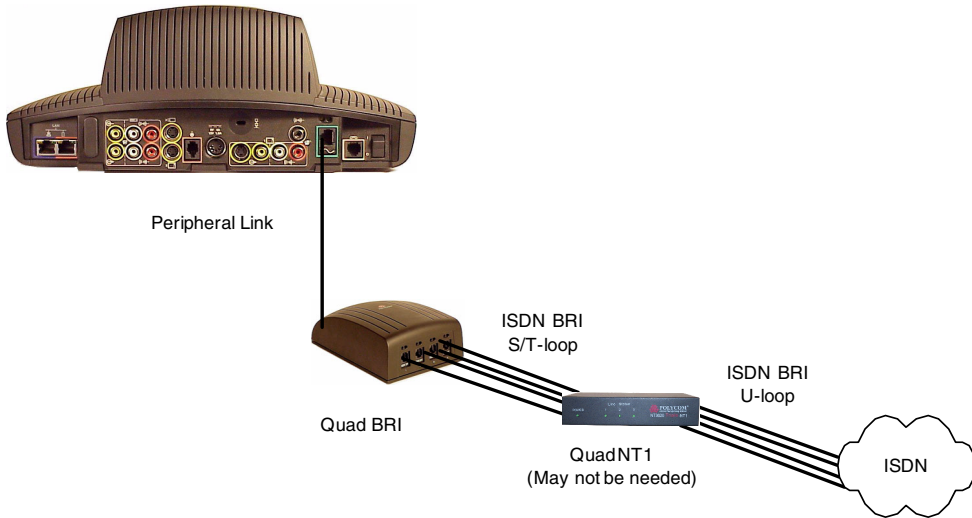

Figure 3-2. Network Configuration (No PBX)

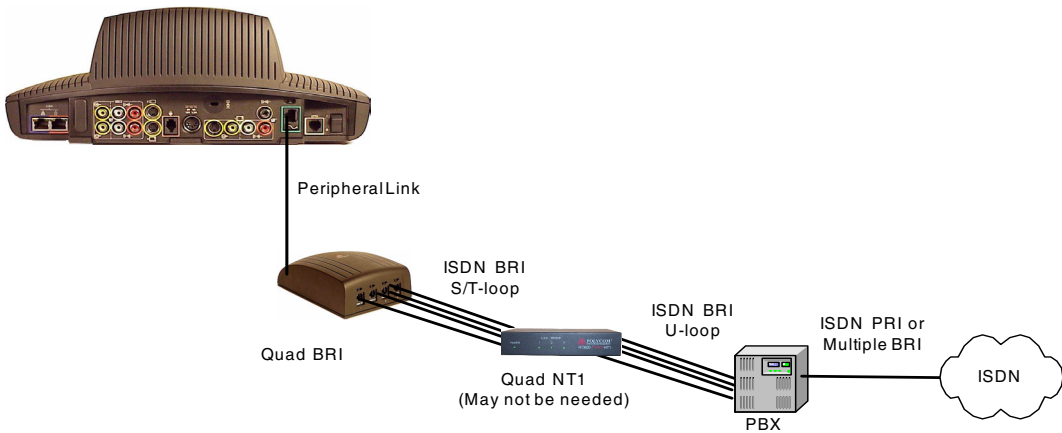

Figure 3-3. Network Configuration (Behind PBX)

For ISDN BRI lines to be used from a PBX to a videoconferencing system, you must do these things in addition to meeting the other requirements.

- ❑ Determine the interface type of the ISDN BRI network module in the PBX (U-loop or S/T-loop). This will determine whether or

not you need an NT1 device between the PBX and the ISDN BRI interface of the videoconferencing system.

- ❑ If the ISDN BRI network module in the PBX is S/T-loop, there is a 500-foot limitation with S/T-loop ISDN. The module may still require a special jack with a resistor.
- ❑ Ensure that the ISDN PRI or multiple BRI lines, on the public side (from the Telco) are provisioned to carry data traffic as if it was connected directly to the videoconferencing systems as discussed in the appropriate sections above. Voice can be added but is not required. Items such as switch protocol, numbering plans, etc. are not necessary as those are determined by the PBX connecting to the ISDN lines from the Telco side.
- ❑ Ensure that the ISDN BRI lines' channels that connect to the videoconferencing systems are mapped appropriately to the channels on the public network side of the PBX that connects to the Telco's ISDN cloud. This is critical also for the success of the inbound calls from systems outside the company to ensure that the ISDN number, provided to the videoconferencing system by the PBX, is routable in the public ISDN cloud and through the PBX to the appropriate videoconferencing system.
- ❑ The ISDN BRI lines between the PBX or other CPE and the videoconferencing system(s) should be provisioned in the same way as ISDN BRI lines that would be connected the system(s) directly from a Telco, as described below.

The following requirements are common to all BRI deployments.

- ❑ ISDN BRI lines need to be configured in the same way as one of the following two Bell Core equivalents:
 - Capability Package R: Circuit Switched Data on 2 B channels. Data capabilities include Calling Number Identification. No voice capabilities are provided.
 - Capability Package S (recommended if system is not behind a PBX): Alternate Voice/Circuit Switched Data on 2 B channels. Data and voice capabilities include Calling Number Identification.
- ❑ Both B channels must carry circuit-switched videoconferencing data (voice can be added but is not required).

- The ISDN BRI service must allow videoconferencing calls to be dialed on either B channel or on both simultaneously.
- The D channel should not permit X.25 packet data.
- The ISDN BRI service must be configured as Terminal Type A.
- The ISDN BRI service must support automatic Terminal Endpoint Identifiers (TEIs).
- The ISDN BRI service must be tariffed and available from the customer's local central office.

DCP (Digital Communication Port) On Lucent Definity ECS

Network Configuration

The **Lucent Definity G3** supports DCP connectivity on **V2 and later**. ViewStation DCP-based systems support the Lucent Definity DCP 2-wire configuration, and requires the DCP ports to be programmed as PDM. No NT1 devices are required with DCP-based systems.

Typically, 4-pair Cat-5 cabling is used between the Definity ECS and the network interface module of the ViewStation, terminated on RJ-45 jacks.

Installation

You can install ViewStation systems in the same room as the Quad BRI network interface module, or you can connect to the Quad BRI network interface module through the building's wiring.

You can locate the system up to 250 feet away from the Quad BRI network interface module, with the following provisions:

- If the distance from the system to the Quad BRI network interface module is less than 50 feet, no additional power is required.

- ❑ If the distance is between 50 and 250 feet, you must use a 9-volt AC/DC transformer to boost power (such as the Digi-Key #T405-ND). Connect the transformer to the Quad BRI network interface module.
- ❑ RJ-45 jacks, connected to 110 blocks or 66 blocks, should be installed in the wiring closet. You can then connect these jacks to the Quad BRI network interface module with the supplied RJ-45 cables.

Configuration

The Polycom DCP-based systems connect to the Definity Communications server through 2-wire digital communications ports (DCP).

Note

Digital Trunk Services are required.

DCP-based systems require up to four 2-wire DCP ports on the Definity server. These ports should reside on the same digital station card in the system. These DCP ports are set up as personal data modules (PDMs).

The following tables show how the data modules should be configured in the Lucent Definity PBX administrative console. Ports 3 and 4 are configured identically with unique extensions for each module, and different port numbers.

Table 3-5. Example Configuration, Data Module 1

Data Extension	6761
Type	pdm
Port	01A0001
ITC	unrestricted
Name	Polycom Channel 1
COS	1
COR	40
TN	1
BCC	1
Remote Loop-Around Test?	n
Secondary data module?	n
Connected to	dte

Table 3-6. Example Configuration: Channel 1, Secondary Data Module 2

Data Extension	6762
Type	pdm
Port	01A0001
ITC	unrestricted
Name	Polycom Channel 1
COS	1
COR	40
TN	1
BCC	1
Remote Loop-Around Test?	n

Table 3-6. Example Configuration: Channel 1, Secondary Data Module 2

Secondary data module?	n
Connected to	dte

Next, you must configure any required hunt groups with a direct inward dialing (DID) numbers, or local directory numbers. This enables other systems to call your system.

Once you have configured the hunt groups, hook up the DCP ports to the system and follow the appropriate system installation procedures. Use the data module extension numbers for the port configurations on the system, and the DID/LDN number for the system's main number.

Note

If you use Equal Access and a long distance reseller, the long distance reseller is probably not providing full 64 KBPS connectivity on long distance calls. In this case, you must set up the Definity to send long distance video calls through a long distance carrier that provides full-bandwidth connections.

You must configure a special COR for the system that uses a different ARS partition group. The ARS partition group will direct all long distance calls through separate routing patterns that have a KICK code configured. This KICK code tells the local carrier which long distance reseller to use and direct the call accordingly.

Site Considerations

When you select a site for videoconferencing equipment, consider the following factors:

Table 3-7. Site Considerations

Factor	For best results
Access to required connections	<p>Ensure that the equipment will be within 6 feet (1.8 m) of power and network connections.</p> <p>Ensure that cables are routed in a way that does not inconvenience people who use the room.</p>
Room lighting	<p>Ensure that the camera will normally point toward an area that is well-lit but not exceptionally bright. Lighting should be diffuse to prevent harsh shadows.</p> <p>If there is a window in the room, ensure that the camera does not normally point toward it. Backlighting makes the speaker appear in silhouette.</p>
Room color and decor	<p>The camera will perform best if the room furnishings are medium to dark in color and do not have polished or reflective surfaces.</p> <p>Ensure that the camera normally points toward an area that is of a medium shade and does not contain detailed, patterned, or brightly-colored elements. For example, a blue or gray wall provides a more effective backdrop than a bright painting.</p> <p>To prevent autofocus problems, place an object somewhere near the center of the camera's default position.</p>
Items in camera range	<p>Ensure that no confidential material can be inadvertently disclosed to callers. For example, ensure that white boards in the conference room are not used for engineering sketches.</p>

Table 3-7. Site Considerations (Continued)

Factor	For best results
Acoustics and background noise	Ensure that there is no audible echo in the room where the camera and microphone(s) will be installed. Carpeting, drapery, and upholstered furniture all help to reduce echo problems. Non-rectangular rooms have less echo than standard conference rooms.
Microphone placement	Refer to the documentation for the specific equipment model for information on where to place the microphone(s).

Predeployment Worksheet

This worksheet will help you get the information you need to install videoconferencing systems on your company's LAN computer network. Complete this worksheet before you start the installation. Once you have this information, refer to this worksheet as needed.

To use your system for LAN-based system management and LAN-based software upgrades you need to know the type of addressing your network uses:

- DHCP (Dynamic Host Configuration Protocol) (Recommended for LAN calls)
- Fixed IP address (Recommended for LAN calls)

IP address for the system _____

Subnet Mask _____

LAN Gateway _____

Check the type of configuration the system uses. Check only one:

- Use DNS Server Configuration
- Use WINS Server Configuration

Host _____

Domain _____

Primary WINS _____

Primary DNS _____

Secondary WINS _____

Secondary DNS _____

To ready your system for LAN-based videoconferencing, you also need to know:

Gatekeeper DNS name or IP address (if necessary) _____

Alias for the videoconferencing system _____

Extension (Terminal ID or E.164 number) for the videoconferencing system _____

SNMP Information (if necessary) _____

If you intend to ready your system for remote management via Simple Network Management Protocol (SNMP), you also need to know:

IP address for the network management station _____

SNMP community string _____

Dialing Directory Information (if necessary) _____

If you intend to use central dialing directories with your videoconferencing system(s), you need to know:

Central Directory (LDAP) Server URL or IP address _____

Port number (default is 389) _____

Directory service root _____

Server type _____

Account password (if you want to auto-publish the account name) _____

Document Server (if necessary) _____

If you intend to use the Document Server option, you need to know:

DNS name or IP address _____

4

Installing Videoconferencing Systems

This chapter provides installation instructions for the ViewStation EX, ViewStation FX, and VS4000 and their network interface modules.

This chapter covers the following topics.

Topic	Page
The Deployment Process	78
Installation Procedures	79
Network Configuration	88
Connecting the System to a PC	91
Placing Test Calls	96

The Deployment Process

The diagram below summarizes the tasks involved in the deployment process. This chapter assumes that the appropriate products have been ordered, and that you have done the appropriate predeployment tasks.

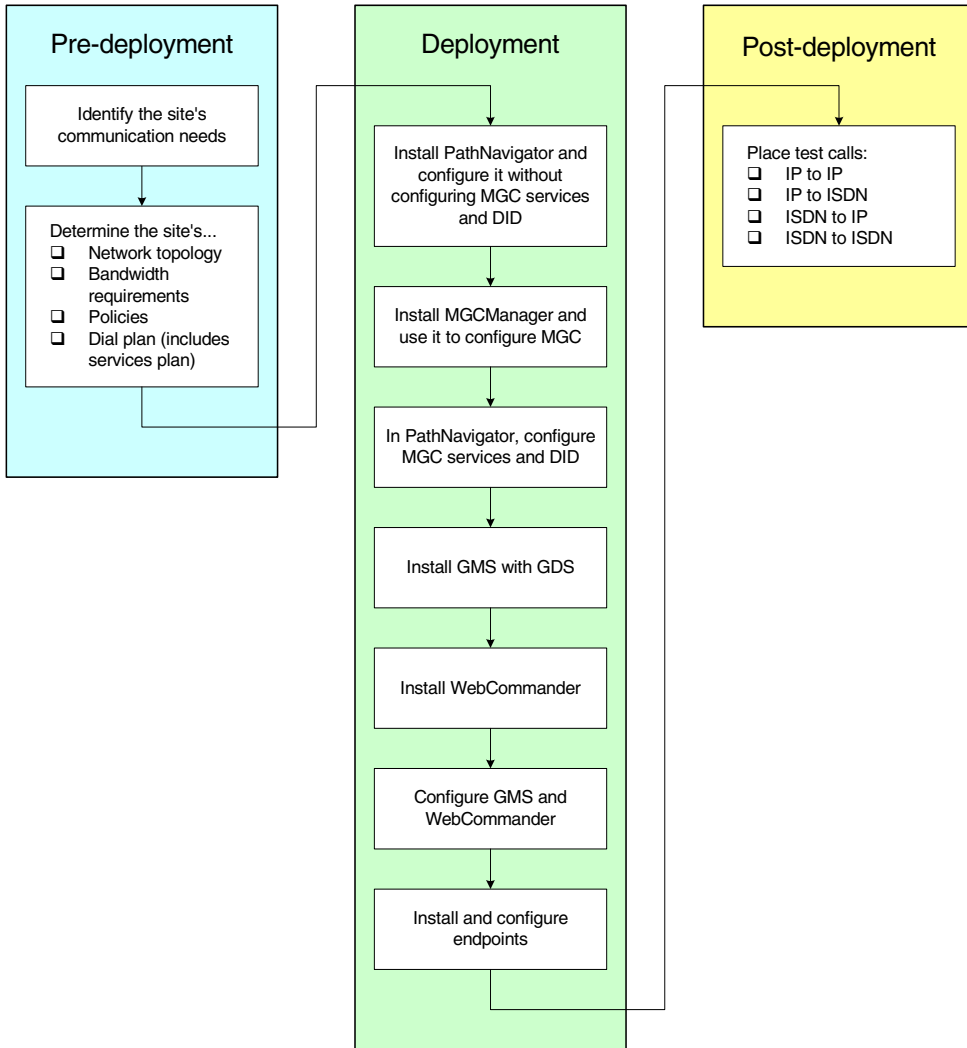

Figure 4-1. The Deployment Process

This chapter discusses installing and configuring endpoints.

Installation Procedures

For basic system installation, please refer to the installation instructions in the appropriate User Guide and the QuickStart cards.

Installing Network Interface Modules

The ViewStation EX, ViewStation FX, and VS4000 may be purchased with either of these network interface modules:

- Quad BRI
- V.35/RS-449/RS-530

In addition, PRI T1 and E1 network interface modules are available with the ViewStation FX and VS4000.

The diagram below shows a general view of how network interface modules are installed.

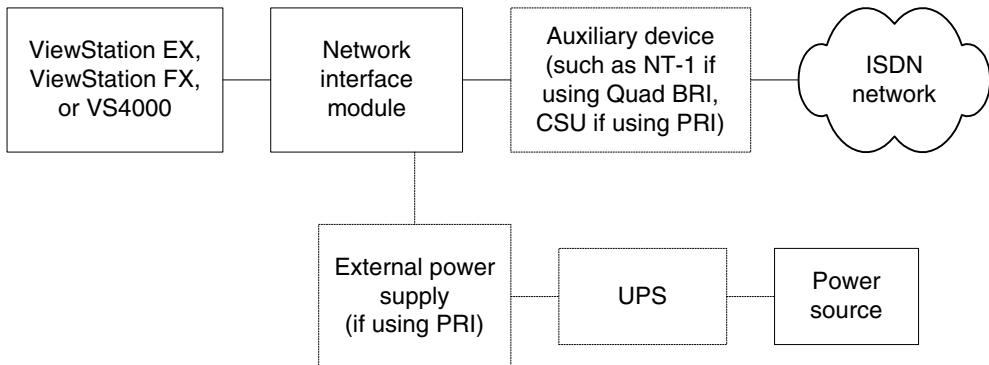

Figure 4-2. Installing Network Interface Modules

Quad BRI Network Interface Module

This section provides information about installing the Quad BRI network interface module. For performance specifications, cable diagrams and pinouts, and other technical information, please refer to [Technical Information, on page 11](#).

NT-1 Device

The Quad BRI network interface module requires an S/T interface. If your site does not use an internal telephone system (PBX), you must connect the Quad BRI module to the ISDN line(s) through a network termination (NT-1) device, which provides the S/T interface.

Cables Used with the Quad BRI Network Interface Module

The network cables are standard CAT5 cables. If you are connecting to a PBX, you may need a crossover cable.

Installation

To connect the Quad BRI network interface module to the system:

1. Make sure your system is turned off.
2. Connect the peripheral side of the Quad BRI network interface module to the system using the supplied network interface cable. This cable is color-coded blue on one end, green on the other.



Figure 4-3. Quad BRI Network Interface Module (Peripheral Side)

3. Connect the network side of the Quad BRI network interface module to the NT-1 device or to the ISDN network, as appropriate.



Figure 4-4. Quad BRI Network Interface Module (Network Side)

4. If you are using an NT-1 device, connect it to the ISDN network.
You are now ready to power on and configure the system.

Installing a PRI Network Interface Module

This section provides information about installing the PRI network interface module. This module is available for the ViewStation FX and VS4000.

For performance specifications, cable diagrams and pinouts, and other technical information, please refer to [Technical Information, on page 11](#).

External Power Supply

If the PRI network interface module loses power, it creates an alarm condition that may result in the service provider disabling the line. The PRI network interface must be connected to the external 12-volt DC power supply so that it does not lose power when the system is powered off. Connect the external power supply to an uninterruptable power supply (UPS) if possible.

The external power supply is mandatory for installations in Europe and is strongly recommended where not mandatory.

You must use an external power supply if you use the internal CSU capability of the PRI T1 network interface module.

Channel Service Unit

In North America, the PRI T1 network interface module can be connected to an external Channel Service Unit (CSU). The CSU isolates the PRI from the network, and continues to transmit a signal to the network even if the PRI network interface module loses power or is disconnected. This prevents the line from being deactivated. A CSU is normally used only when the PRI network interface module is connected directly to a telephone company switch, not a PBX.

Outside North America, CSUs are not used with PRI network interface modules.

If you use an external CSU, connect an RJ-45 cable from the CPE equipment side of the CSU to the PRI network interface module.

ADTRAN Atlas 800 Plus E1 Module

Firmware

If you are using an ADTRAN Atlas 800 Plus E1 Module, it must use firmware version G03b or later.

Channel Restarts

Wait two to three minutes after the endpoint has been powered on and the PRI status icon has turned green before making or receiving calls with the ADTRAN Atlas 800 Plus. This allows time for channel restarts on the ADTRAN Atlas 800 Plus E1 module. If you place a call before channel restarts are complete, a **Network Congestion** message appears on the system. Incoming calls during this time will receive a **Far Site Busy** message.

If You Are Connecting to a PBX

- Some PBXs require a crossover cable.
- The PBX must provide the clock signal and act as the network side for layers 1, 2, and 3.
- QSIG signaling (PSS1) is not supported. However, a PRI network interface module can be connected to a PISN through a gateway using ETSI DSS1 signaling.

Cables Used with the PRI Network Interface Module

The following cables may be used with the PRI network interface module.

- Peripheral link cable:** The peripheral link cable does not fit into a standard RJ-45 network port. You can, however, use it to connect any Polycom network interface module to the system.
- PBX crossover cable:** An RJ-45 crossover cable may be required when connecting the PRI network interface module to a PBX or other third-party network access device.
- PRI Cable extension:** You can purchase a cable adapter kit to extend the distance between your system and the PRI network interface module.
- 75 Ω coaxial adapter:** The PRI E1 line termination is 120 Ω . In some areas, however, the E1 network connection is via a 75 Ω coaxial cable. The PRI network interface module does not directly support this, but you can obtain passive adapter devices from various vendors.

Installation

To install the PRI network interface module:

1. Ensure that the system is powered off.
2. Connect peripheral side of the PRI network interface module to the system using the supplied cable. Figure 4-5 shows the peripheral side of the PRI network interface module.

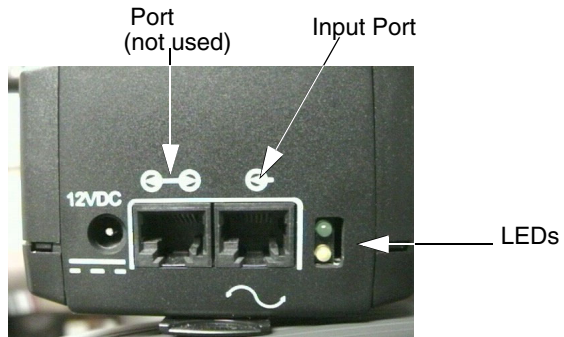

Figure 4-5. PRI Network Interface Module (Peripheral Side)

3. Connect the 12-volt DC power supply to the PRI network interface module and then to the UPS or wall outlet.
4. Connect the PRI network interface module to the ISDN network.

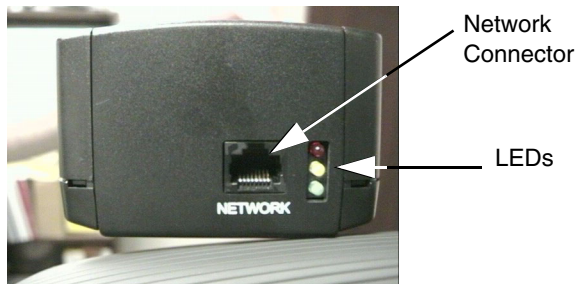

Figure 4-6. PRI Network Interface Module (Network Side)

You are now ready to power on and configure the system.

Installing a V.35/RS-449/RS-530 Network Interface Module

Cables Used with the V.35/RS-449/RS-530 Network Interface Module

The network interface module connects to the system using a cable that is not interchangeable with standard RJ-45 to RJ-45 cables.

The following optional cables used to connect the V.35/RS-449/RS-530 module to the DCE are available from the Polycom Web store:

- V.35 "Y" cable—HD-44M to DB-25M/RS-366 and M34 "Winchester" V.35
- RS-449/422 "Y" cable—HD-44M to DB-25M/RS-366 and DB-37M/RS-449/422
- Ascend cable—HD-44M to HD-44M

Cable for Direct Connect. Direct Connect users can choose to have the local system answer a video call when it detects data from a remote site, or hang up when it detects lack of data from the remote site. This Direct Connect signal lead would be in addition to existing V.35/RS-449/RS-530 signal leads that control answer/hang up call states.

Installation

To install V.35/RS-449/RS-530 Network Interface Module:

1. Make sure the system is turned off.
2. Connect the peripheral side of the network interface module to the system. Refer to Figure 4-7.

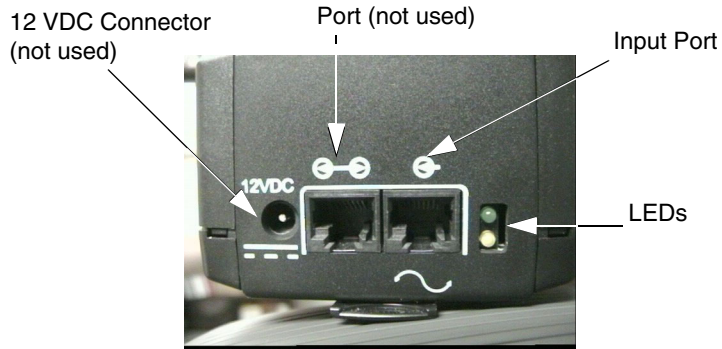

Figure 4-7. V.35/RS-449/RS-530 Network Interface Module (Peripheral Side)

3. Connect the network side of the network interface module to the DCE, shown in Figure 4-8 below. If you have only one cable, connect it to port 1.



Figure 4-8. V.35/RS-449/RS-530 Network Interface Module (Network Side)

Note

If your DCE does not use dialing, do not use the RS-366 (DB-25M) connector.

Network Configuration

The following paragraphs give information about configuring the ViewStation EX, ViewStation FX, and VS4000 systems for the ISDN network.

On a PRI T1 Network: Configuring the CSU

If you use an external CSU, you must specify the following information on the **PRI Setup** screen (**System Info > Admin Setup > Video Network > IMUX > PRI Network > PRI Setup**):

1. In the **CSU** field, select **External**.
2. In the **Line Buildout** field, select the length of the cable that connects the PRI network interface module to the CSU.

You can also configure the T1 PRI network interface module to act as a CSU. To do this, the external power supply must be connected.

To use the T1 PRI network interface module as an internal CSU, you must specify the following information on the **PRI Setup** screen (**System Info > Admin Setup > Video Network > IMUX > PRI Network > PRI Setup**):

1. In the **CSU** field, select **Internal**.
2. In the **Line Buildout** field, select an appropriate dB setting. The telephone company usually determines the dB value by measuring the characteristics of the line. If an external CSU was previously used, use the setting selected for that CSU. Otherwise, start with 0.

Firewall and NAT Issues

A firewall protects an organization's network by controlling data traffic from outside the network. Different types of firewalls use different techniques to provide network security, but unless the firewall is designed to work with H.323 videoconferencing equipment, it will prevent successful videoconferencing because it is designed to prevent unsolicited data from entering the network. From a functional perspective, it blocks incoming calls, and it prevents outgoing calls by blocking the call signalling from the external endpoint when the two endpoints begin the signal transaction required to set up the call.

Network Address Translation (NAT) network environments use internal IP addresses for the devices within the network, while using one external IP address to communicate with the outside world (Wide Area Network). The NAT router accepts incoming data and forwards it to the appropriate endpoint. This provides a degree of network security, as the internal IP addresses do not provide access from outside the network.

Firewalls and NAT are often used together.

Configuring the System to Operate Behind a Firewall

To make calls through a firewall, you must open the following ports and assign them to the videoconferencing system:

Table 4-1. Firewall Ports to Open for Videoconferencing

Port	Used for
389 (TCP)	ILS registration
1503 (TCP)	Microsoft NetMeeting T.120 data sharing
1718 (UDP)	Gatekeeper discovery
1719 (UDP)	Gatekeeper RAS (must be bidirectional)
1720 (TCP)	H.323 call set-up (must be bidirectional)
1731 (TCP)	Audio call control (must be bidirectional)
3230-3235 (TCP/UDP)	Signalling and control for audio, call, video, and data/FECC
3603 (TCP)	Web interface

Configuring the System to Operate Behind a NAT

The **System is behind a NAT** option allows the user make calls outside the internal network.

At this time, it is not possible to make videoconferencing calls within the internal network when the **System is behind a NAT** option is selected. To make videoconferencing calls within the network, users must deselect the **System is behind a NAT** option before making the call.

1. Determine the NAT's external (WAN) IP address.
2. Determine the IP address of the system. This can be found in the **System Information** screen.
3. Go to **Quality of Service and Firewalls** screen (**System Info > Admin Setup > LAN/H.323 > H.323 > QOS**).
4. Select **Use Fixed Ports**.
5. Select **System is behind a NAT**.
6. Enter the NAT's external IP address into the **NAT outside (WAN) address** field.
7. Write down the Fixed TCP and UDP port numbers displayed on this screen. The default values are:
TCP: 3230 to 3231
UDP: 3230 to 3235
8. Reset the firewall's fixed ports from step 4 to be permanently open, and redirect them to the IP address of your system.
9. To accept incoming calls, open and redirect port 1720 to the IP address of your system.

Connecting the System to a PC

In some situations you may want to connect a laptop directly to the ViewStation EX, ViewStation FX, or VS4000. This allows you to:

- Update software on a system that is not connected to a LAN.
- Use IP-based functions such as PolySnap or Visual Concert PC with a system that is not connected to a LAN.
- Upload Microsoft PowerPoint files to the system if you do not have a Visual Concert data collaboration unit.
- Connect a PC to the LAN through a LAN-connected system if there is only one LAN connection in the room.

This section explains how to set up and connect your PC to a ViewStation EX, ViewStation FX, or VS4000.

PC Requirements

The system requirements for connecting a PC to the system are:

- Microsoft Windows 95, 98, 2000, or NT
- Desktop PC connected to a LAN or laptop with a 10 Mbps or 100 Mbps Ethernet LAN card
- Ethernet cable
- Microsoft Internet Explorer 4.0 or higher (recommended) or Netscape 4.5 or higher

Connecting the PC to the LAN Through the ViewStation EX, ViewStation FX, or VS4000

Do this if you need to use the system to provide LAN connectivity for your PC.

1. Ensure that the PC and the system are both powered off.
2. Connect the system to the LAN using the LAN connector and cable.
3. Connect the blue RJ-45 cable into the blue PC port on the back of the system and to the Ethernet port on your computer.
4. Power on the system.
5. Select **System Info > Admin Setup > LAN/H.323 > LAN/Intranet** to configure the system's LAN/H.323 settings. The **LAN & Intranet** screen appears.
6. If your LAN does not use DHCP, go to step 9.
7. If your LAN uses DHCP, select **Client** in the **DHCP** field to enable the system to obtain an IP address from a server on your network.
8. After you have changed the DHCP settings, a message lets you know that the system will have to be reset in order to save the changes. Select **Yes**. Another message informs you that the system is about to restart.
9. Select the **System Info** icon to go to the **System Information** screen. Your system's IP address should appear in the **IP Address** field.

You have finished this procedure. The rest of this procedure applies to LANs that do not use DHCP.

Note

If the IP address field displays "...waiting..." the system did not get an address from the LAN. Check the LAN connection on the back of the system and try again. When the system is properly connected, the green light on the connector is illuminated and the orange light blinks.

10. Select **Off** in the **DHCP** field and manually enter the IP address, subnet mask, and gateway address provided by your system administrator.
11. Turn on your PC and make sure it is properly configured.
12. After you have changed the DHCP settings, a message lets you know that the system will have to be reset in order to save the changes. Select **Yes**. Another message informs you that the system is about to restart.

Connecting the System to a PC off the LAN

Do this if you need to use IP-based functions (display desktop, do a software update, use PolySnap) on a system that is not connected to a LAN.

Caution

Your system must be configured as a DHCP server for this procedure. Do not use this procedure if the equipment is connected to a LAN.

Note

To set your system as a DHCP server, the option **Allow System to be a DHCP Server** must have been enabled during a software upgrade of your system.

1. Ensure that the PC and the system are both powered off.
2. Connect the blue RJ-45 cable into the blue PC port on the back of the system and to the Ethernet port on your computer.
3. Power on the system and the PC.
4. Select **System Info > Admin Setup > LAN/H.323 > LAN/Intranet** on the ViewStation.
5. Press the **Up** arrow on the remote control to go to the **DHCP** field and set it to **Server**. The system displays the message "The system will now issue IP addresses to other PCs on the LAN. Continue?"

Caution

Do not use this setting if your ViewStation is on a LAN. If you do, the ViewStation will provide IP addresses to the other computers on the LAN even though the LAN already has a DHCP server. Your IT personnel and system administrators will have to repair any network problems this causes.

6. Select **Yes** if you are absolutely certain you want to set your system as a DHCP server.
7. Press **Menu**. The following message will appear: "Power must be reset to save changes. Continue?" Select **Yes**.
8. Your ViewStation will automatically restart. It will now act as a DHCP server and will provide IP addresses to one or more PCs.
9. Go to the **System Information** screen. You should see an IP address of 1.1.1.2, which is the IP address of your ViewStation. If your PC uses Windows 2000, go to step 14.
10. For Windows 95, Windows 98, or Windows NT 4.0, right-click the **Network Neighborhood** icon, and then right-click **Properties**.
11. When the **Network** box appears, select the **Configuration** tab, then double-click **TCP/IP**.
12. Select the **IP Address** tab. Make sure the **Obtain an IP Address Automatically** button is selected. Then click **OK**.
13. Go to step 18.
14. For Windows 2000, right-click the **My Network Places** icon, and then right-click **Properties**.
15. In the **Network and Dial-up Connections** window, right-click **Local Area Connection**, and select **Properties**.
16. In the **Local Area Connection Properties** window, double-click **Internet Protocol (TCP/IP)**.
17. In the **Internet Protocol (TCP/IP) Properties** window, make sure the **Obtain an IP Address Automatically** button is selected. Then click **OK**.
18. Restart your PC.

Placing Test Calls

To verify that you have installed the endpoint equipment correctly, test each unit as follows:

- Place an ISDN call from the unit.
- Place an IP call from the unit.
- From a suitable endpoint, place an ISDN call to the unit.
- From a suitable endpoint, place an IP call to the unit.

If you are able to complete all calls successfully, the unit is ready for use.

5

Supporting Advanced Users

This chapter describes features that are available but not widely used. Inexperienced users may need assistance with these features.

This chapter covers the following topics.

Topic	Page
Multiple-Monitor Mode	98
RS-232 Interface	105

Multiple-Monitor Mode

The following table describes each monitor's expected behavior in systems using one to four monitors.

Table 5-1. Expected Display for Each Monitor

Condition	Monitor					System VGA or Visual Concert VGA
	PIP	1	2	3	4	
Booting	None	Logo	Logo	Logo	Logo	JPEG
Test pattern	None	Color bar	Color bar	Color bar	Color bar	
Single-monitor mode, no VGA						
Not in a call: main/UI	Near	Main				
Not in a call: graphic	None	Graphic				
Point-to-point call: call connect	Near	Far				
Point-to-point call: main/UI	Far	Main				
Point-to-point call: graphic	Far	Graphic				
Multipoint call: main/UI	Last talker	Main				
Multipoint call: graphic	Last talker	Graphic				
Multipoint call: discussion mode	None	Cont. presence				
Multipoint call: presentation mode	None	Cont. presence				
Multipoint call: full-screen mode	Near	Last talker				
Single-monitor mode, VGA						
Not in a call: main/UI	Near	Main				No change
Not in a call: graphic	None	Near				Graphic

Table 5-1. Expected Display for Each Monitor (Continued)

Condition	Monitor				System VGA or Visual Concert VGA
	PIP	1	2	3	
Point-to-point call: call connect	Near	Far			No change
Point-to-point call: main/UI	Far	Main			No change
Point-to-point call: graphic	Near	Far			Graphic
Multipoint call: main/UI	Last talker	Main			No change
Three-way call: graphic	Near	Far			Graphic
Four-way call: graphic	None	Cont. presence			No change
Multipoint call: discussion mode	None	Cont. presence			No change
Multipoint call: presentation mode	None	Cont. presence			No change
Multipoint call: full-screen mode	Near	Last talker			No change
Sleep mode	None	None			None
Two-monitor mode, no VGA					
Not in a call: main/UI	Near	Main	Near		
Not in a call: graphic	None	Near	Graphic		
Point-to-point call: call connect	None	Far	Near		
Point-to-point call: main/UI	Far	Main	Far		
Point-to-point call: graphic	Near	Far	Graphic		
Multipoint call: main/UI	Last talker	Main	Last talker		

Table 5-1. Expected Display for Each Monitor (Continued)

Condition	Monitor				System VGA or Visual Concert VGA
	PIP	1	2	3	
Multipoint call: graphic	None	Cont. presence	Graphic		
Three-way call: discussion mode	Near	Far	Far (2)		
Three-way call: presentation mode	Near	Far	Far (2)		
Three-way call: full-screen mode	Near	Far	Far (2)		
Four-way call: discussion mode	None	Cont. presence	Near		
Four-way call: presentation mode	None	Cont. presence	Near		
Four-way call: full-screen mode	None	Last talker	Near		
Two-monitor mode, VGA					
Not in a call: main/UI	Near	Main	Near		
Not in a call: graphic	None	Near	None		Graphic
Point-to-point call: call connect	None	Far	Near		
Point-to-point call: main/UI	Far	Main	Far		
Point-to-point call: graphic	None	Far	Near		Graphic
Multipoint call: main/UI	Last talker	Main	Last talker		
Three-way call: graphic	Near	Far	Far (2)		Graphic
Three-way call: discussion mode	Near	Far	Far (2)		
Three-way call: presentation mode	Near	Far	Far (2)		

Table 5-1. Expected Display for Each Monitor (Continued)

Condition	Monitor				System VGA or Visual Concert VGA
	PIP	1	2	3	
Three-way call: full-screen mode	Near	Far	Far (2)		
Four-way call: graphic	None	Cont. presence	Last talker		Graphic
Four-way call: discussion mode	None	Cont. presence	Last talker		
Four-way call: presentation mode	None	Cont. presence	Last talker		
Four-way call: full-screen mode	None	Last talker	Near		
Three-monitor mode, no VGA					
Not in a call: main/UI	None	Main	Near	None	
Not in a call: graphic	None	Near	Graphic	None	
Point-to-point call: call connect	None	Far	Near	None	
Point-to-point call: main/UI	Far	Main	Near	Far	
Point-to-point call: graphic	None	Far	Graphic	Near	
Three-way call: main/UI	Last talker	Main	Far	Far (2)	
Three-way call: graphic	Near	Far	Graphic	Far (2)	
Three-way call: discussion mode	None	Far	Near	Far (2)	
Three-way call: presentation mode	None	Far	Near	Far (2)	
Three-way call: full-screen mode	None	Far	Near	Far (2)	
Four-way call: main/UI	Last talker	Main	Far (2)	Far (3)	

Table 5-1. Expected Display for Each Monitor (Continued)

Condition	Monitor					System VGA or Visual Concert VGA
	PIP	1	2	3	4	
Four-way call: graphic	None	Cont. presence	Graphic	Last talker		
Four-way call: discussion mode	Near	Far	Far (2)	Far (3)		
Four-way call: presentation mode	Near	Far	Far (2)	Far (3)		
Four-way call: full-screen mode	Near	Far	Far (2)	Far (3)		
Three-monitor mode, VGA						
Not in a call: main/UI	None	Main	Near	None		
Not in a call: graphic	None	Near	None	None		Graphic
Point-to-point call: call connect	None	Far	Near	None		
Point-to-point call: main/UI	Far	Main	Near	Far		
Point-to-point call: graphic	None	Far	Near	None		Graphic
Three-way call: main/UI	Last talker	Main	Far	Far (2)		
Three-way call: graphic	None	Far	Near	Far (2)		Graphic
Three-way call: discussion mode	None	Far	Near	Far (2)		
Three-way call: presentation mode	None	Far	Near	Far (2)		
Three-way call: full-screen mode	None	Far	Near	Far (2)		
Four-way call: main/UI	Last talker	Main	Far (2)	Far (3)		
Four-way call: graphic	Near	Far	Far (2)	Far (3)		Graphic

Table 5-1. Expected Display for Each Monitor (Continued)

Condition	Monitor					System VGA or Visual Concert VGA
	PIP	1	2	3	4	
Four-way call: discussion mode	Near	Far	Far (2)	Far (3)		
Four-way call: presentation mode	Near	Far	Far (2)	Far (3)		
Four-way call: full-screen mode	Near	Far	Far (2)	Far (3)		
Four-monitor mode, no VGA						
Not in a call: main/UI	None	Main	Near	None	None	
Not in a call: graphic	None	Near	Graphic	None	None	
Point-to-point call: call connect	None	Far	Near	None	None	
Point-to-point call: main/UI	Far	Main	Near	Far	None	
Point-to-point call: graphic	None	Far	Graphic	Near	None	
Three-way call: main/UI	Last talker	Main	Near	Far (2)	Far	
Three-way call: graphic	None	Far	Graphic	Far (2)	Near	
Three-way call: discussion mode	None	Far	Near	Far (2)	None	
Three-way call: presentation mode	None	Far	Near	Far (2)	None	
Three-way call: full-screen mode	None	Far	Near	Far (2)	None	
Four-way call: main/UI	Last talker	Main	Far	Far (2)	Far (3)	
Four-way call: graphic	Near	Far	Graphic	Far (2)	Far (3)	
Four-way call: discussion mode	None	Far	Near	Far (2)	Far (3)	

Table 5-1. Expected Display for Each Monitor (Continued)

Condition	Monitor					System VGA or Visual Concert VGA
	PIP	1	2	3	4	
Four-way call: presentation mode	None	Far	Near	Far (2)	Far (3)	
Four-way call: full-screen mode	None	Far	Near	Far (2)	Far (3)	
Four-monitor mode, VGA						
Not in a call: main/UI	None	Main	Near	None	None	
Not in a call: graphic	None	Near	None	None	None	Graphic
Point-to-point call: call connect	None	Far	Near	None	None	
Point-to-point call: main/UI	Far	Main	Near	Far	None	
Point-to-point call: graphic	None	Far	Near	None	None	Graphic
Three-way call: main/UI	Last talker	Main	Near	Far (2)	Far	
Three-way call: graphic	None	Far	Near	Far (2)	None	Graphic
Three-way call: discussion mode	None	Far	Near	Far (2)	None	
Three-way call: presentation mode	None	Far	Near	Far (2)	None	
Three-way call: full-screen mode	None	Far	Near	Far (2)	None	
Four-way call: main/UI	Last talker	Main	Near	Far (2)	Far (3)	
Four-way call: graphic	None	Far	Near	Far (2)	Far (3)	Graphic
Four-way call: discussion mode	None	Far	Near	Far (2)	Far (3)	

Table 5-1. Expected Display for Each Monitor (Continued)

Condition	PIP	Monitor				System VGA or Visual Concert VGA
		1	2	3	4	
Four-way call: presentation mode	None	Far	Near	Far (2)	Far (3)	
Four-way call: full-screen mode	None	Far	Near	Far (2)	Far (3)	

RS-232 Interface

RS-232 Control Mode

In Control Mode, the ViewStation EX, ViewStation FX, or VS4000 is under the control of the PC or other device connected to its RS-232 port.

RS-232 Pass-Thru Mode

Pass-Thru Mode allows two endpoints to pass data from one unit's RS-232 port to the other unit's RS-232 port, using the H.320 call as the connection. Pass-Thru Mode is a proprietary feature that is only available if both endpoints are ViewStation EX, ViewStation FX, or VS4000 systems. Pass-Thru Mode is available only in H.320 mode (ISDN or V.35/RS-449/RS-530) calls. It is not available in H.323 (IP) video calls or multi-point calls.

Note

When using Pass-Thru Mode, both endpoints must be set to the same baud rate.

Both endpoints in Pass-Thru Mode—Two stations set to Pass-Thru Mode behave as a null-modem between their respective externally connected devices. Data from the RS-232 port on one endpoint is pushed through the call to the other endpoint, and then transmitted to the endpoint's RS-232 port. The data channel speed is dynamically allocated. The maximum data flow rate is based on the bandwidth of the call.

Because data throughput has priority over video throughput, video bandwidth may be restricted to support data requirements. Audio is not compromised.

Far-site endpoint in Control Mode—If the near site is set to Pass-Thru Mode and the far site is set to Control Mode, the far-site device acts as a slave under the control of the device connected to the near-site endpoint's RS-232 port.

The following table summarizes the port operation based on the RS-232 mode configured by each endpoint.

Table 5-2. RS-232 Control and Pass-Thru Modes

Near-Side Mode	Far-Side Mode	Resulting Operation
Control	N/A	Near-side CLI (Command Line Interface)
Pass-Thru	Control	The near-side controls the CLI of the far side
Pass-Thru	Pass-Thru	The data is passed in full-duplex mode from the near-side RS-232 port to the far-side RS-232 port

Flow Control

The ViewStation EX, ViewStation FX, and VS4000 support hardware flow control. Users should make sure that hardware flow control settings are consistent between the system and the external devices on both sides of the connection.

Configure the System for RS-232 Operation

To configure your system to use the RS-232 interface:

1. Select **System Info > Admin Setup > Software/Hardware > RS-232** to display the **RS-232** screen
2. Configure the **Baud Rate**.
3. Configure the **RS-232 Mode**. Select **Control Mode** to allow the system to act as a slave device under the control of the RS-232 device using the Remote Control API, or select **Pass-Thru Mode** to do either of these:
 - Allow the system to act as a master device, controlling the ViewStation EX, ViewStation FX, or VS4000 at the far end.
 - Configure the system as a null-modem, using the RS-232 port as a data channel.
4. Configure **Flow Control**.

Command Line Interface (CLI)

Several communications programs (such as HyperTerminal) are available to provide a command line interface (CLI) to control the system via the RS-232 interface. The following explains how to start a HyperTerminal session on your PC.

To start a HyperTerminal session:

1. From your PC desktop, select **Start > Programs > Accessories > Communications > HyperTerminal**.
2. In the **Connection Description** window, enter a **Name**. Select an icon. Click **OK**.
3. In the **Connect To** window, from the **Connect Using** list, select the proper comport (usually com1). Click **OK**.

4. In the **Com1 Properties** window, under **Port Settings**, select the following settings:
 - Baud rate should match that of the system (default is 9600)
 - Data bits = 8
 - Parity = none
 - Stop bits = 1
 - Flow control setting should match that of the system. **None** is the default. Some third-party control panels may require to be set to **Hardware**.
5. Click **OK**.

6

Testing and Troubleshooting

This chapter describes how to do post-deployment functional tests and how to identify and correct problems.

This chapter covers the following topics.

Topic	Page
Indicator Lamps	109
Fault Isolation	113
ISDN Error Codes	114

Indicator Lamps

The ViewStation EX, ViewStation FX, and VS4000 and their network interface modules have indicator lamps (LEDs) that can help you to determine whether the equipment is performing properly, and to diagnose problems if it is not. The following sections define the various indications provided by the lamps.

Indicator Lamps on the PRI Network Interface Module

The PRI network interface module uses lamps on both the network side and the peripheral side to provide status indications.

Note

The PRI network interface module is not available with the ViewStation EX.

Table 6-1. PRI indicator lamps - Network side

Lamp behavior	Meaning
Amber LED on	Software update starting: Data is being transferred to the PRI network module (approximately 90 seconds)
Amber LED and green LED on	Software update in progress: The module is being updated (a few seconds)
Red LED on momentarily.	Software update finishing
T1 only: Yellow LED on momentarily.	Software update finishing
Green LED on	Software update complete, system synchronized with network and fully operational
Red LED blinking	No power on the line: network cable is unconnected, or upstream switch or PBX port is deactivated
Red LED on	Network cable is connected and power on the line, but no clock syn
Yellow LED blinking	E1: Receiving Remote Alarm Indication (RAI) from network with Cyclic Redundancy Check (CRC) errors
Yellow LED on	T1: Waiting for a timer to elapse E1: Receiving RAI from network with no CRC errors

Table 6-1. PRI indicator lamps - Network side (Continued)

Lamp behavior	Meaning
Red and yellow LEDs on	Receiving clock sync, and receiving AIS Alarm Indication Signal (unframed all-ones)
Green LED on	System fully synchronized with the network and ready to use

Table 6-2. PRI indicator lamps - Peripheral side

Lamp behavior	Meaning
Amber LED on	Booting (brief) or starting software update (over 60 seconds)
Amber and green LEDs on	Software update in progress
Green LED on	Ready ^a

a. If the PRI network interface module is connected to an external power source, the green LED turns on after several seconds, even if the peripheral link cable is not connected.

Indicator Lamps on the Quad BRI Network Interface Module

The Quad BRI network interface module uses pairs of indicator lamps associated with each BRI line to provide status indications. The table below shows the meanings of the LED pair associated with one line. Note that the lines in use may not always display the same status. If this is the case, you should investigate the cause. .

Table 6-3. Quad BRI Indicator Lamps

Indication	Meaning
Green LED	Off = no connection to the switch, or no clock On = clock is synchronized with the switch
Yellow LED	Off = in reset mode, booting On = active
Both LEDs on	Normal operation

Indicator Lamps on the V.35/RS-449/RS-530 Network Interface Module

The V.35/RS-449/RS-530 network interface module uses lamps on both the network side and the peripheral side to provide status indications.

Table 6-4. V.35/RS-449/RS-530 Indicator Lamps - Network Side

Lamp behavior	Meaning
Amber LED on	Indicates that a port is properly connected to an active DCE and is receiving a network clock
Green LED on	The system is in a call

Table 6-5. V.35/RS-449/RS-530 Indicator Lamps - Peripheral Side

Lamp behavior	Meaning
Green and amber LEDs flash once, then turn on	System booting
Amber LED on	System is communicating with the network interface module
Green LED on	System is communicating with the network

Fault Isolation

The following table lists symptoms, causes, and corrective actions for equipment malfunctions.

Table 6-6. Fault Isolation

Problem	Possible cause	Corrective action
Monitor screen remains blank	Monitor is not connected to power	Check all cables to equipment
	Monitor is not connected to endpoint equipment	
	Endpoint equipment is not connected to power	
	System is in sleep mode	Lift the remote control and point it toward the remote sensor
Reboot process does not end	Flash memory is full	Turn off power to the system, then press and hold the reset switch while turning on power
Reboot process halts without finishing	File corruption	Turn off power to the system, then press and hold the reset switch while turning on power
System displays a Softupdate screen	No power at PRI network interface module	Check cable between endpoint and PRI network interface module
PBX does not accept calls of numbering type “unknown” from PRI network interface module	Configuration problem	Refer to the appropriate User Guide for information about configuring the PRI

ISDN Error Codes

The following table describes codes that the ISDN switch sends to the router to indicate call status. Although the codes are standardized, each ISDN service provider defines them differently. Because of this, the definitions in the table may not exactly match the messages that appear on your monitor.

Table 6-7. ISDN Call Status Codes

Code	Cause	Definition
1	Unassigned number	The switch received the sent ISDN number in the correct format, but no destination equipment uses the number.
2	No route to specified transit network	The ISDN exchange does not recognize the intermediate network through which to route the call.
3	No route to destination	The intermediate network through which the call is routed does not serve the destination address.
6	Channel unacceptable	The specified channel does not provide adequate service quality to accept the requested connection.
7	Call awarded and delivered	The user is assigned an incoming call that is being connected to a call channel that has already been established for this user and this type of call.
16	Normal call clearing	The originator or receiver of the call has requested that it be cleared.
17	User busy	All B channels are in use; the called system acknowledges the connection request, but is unable to accept the call.
18	No user responding	The destination equipment does not respond to the call, so the connection cannot be completed.
19	No answer from user (user alerted)	The destination equipment did not complete the connection within the prescribed time after responding to the connection request. The problem is at the remote end of the connection.

Table 6-7. ISDN Call Status Codes (Continued)

Code	Cause	Definition
21	Call rejected	The destination equipment is capable of accepting the call, but has rejected it for an unknown reason.
22	Number changed	The ISDN number used to set up the call is no longer valid. (The diagnostic field of the message may return an alternate address assigned to the called equipment.)
26	Non-selected user clearing	The destination is capable of accepting the call, but did not assign it to the user.
27	Destination out of order	A signaling message cannot be delivered because the interface is not functioning correctly, and the destination cannot be reached. This condition might be temporary; for example, remote equipment might be turned off.
28	Invalid number format	Destination address was incomplete or presented in an unrecognizable format, which prevented the connection from being established.
29	Facility rejected	The network cannot provide the facility requested by the user.
30	Response to STATUS INQUIRY	The equipment returns this message when it receives a STATUS INQUIRY message.
31	Normal, unspecified	A normal event has occurred with no standard cause applying. No resulting action is required.
34	No circuit/channel available	The call cannot be taken because no appropriate channel is available to establish the connection.
38	Network out of order	A network problem prevented the call from reaching its destination. Attempts to reconnect will probably fail until the network problem is corrected.
41	Temporary failure	A network error occurred. The problem will be resolved shortly. Attempts to reconnect may succeed.

Table 6-7. ISDN Call Status Codes (Continued)

Code	Cause	Definition
42	Switching equipment congestion	The destination cannot be reached because the network switching equipment is temporarily overloaded.
43	Access information discarded	The requested access information cannot be provided by the network. The diagnostic message may explain the problem.
44	Requested circuit/channel not available	The remote equipment cannot provide the requested channel. This may be temporary.
47	Resource unavailable, unspecified	An unknown problem prevents the remote equipment from providing the requested resource.
49	Quality of service unavailable	The network cannot provide the requested quality of service (as defined by CCITT recommendation X.213). This may be a subscription problem.
50	Requested facility not subscribed	The remote equipment is capable of providing the requested supplementary service, but is not subscribed to it.
57	Bearer capability not authorized	The caller has requested a bearer capability that the network can provide, but the user is not authorized to use. This may be a subscription problem.
58	Bearer capability not presently available	The network normally provides the requested bearer capability, but cannot provide it now. This may be a temporary network problem or a subscription problem.
63	Service or option not available, unspecified	An unspecified problem prevents the network or remote equipment from providing the requested service or option. This might be a subscription problem.
65	Bearer capability not implemented	The network is not capable of providing the bearer capability requested by the user.
66	Channel type not implemented	The requested channel type is not supported by the equipment sending this code.

Table 6-7. ISDN Call Status Codes (Continued)

Code	Cause	Definition
69	Requested facility not implemented	The remote equipment is not capable of providing the requested supplementary service.
70	Only restricted digital information bearer is available	The network is unable to provide unrestricted digital information over bearer capability.
79	Service or option not available, unspecified	The network or remote equipment is unable to provide the requested service option for an unspecified reason. This might be a subscription problem.
81	Invalid call reference value	The remote equipment received a call with a call reference that is not currently in use on the user-network interface.
82	Identified channel does not exist	The receiving equipment is requested to use a channel that is not activated on the interface for calls.
83	A suspended call exists but this call identity does not	The network received a call resume request that contained a call identity information element that does not match any suspended call.
84	Call identity in use	The network received a call suspend request that contained a call identity information element for a call that is already suspended.
85	No call suspended	The network received a call resume request when there was not a suspended call pending. This might be a transient error that will be resolved by successive call retries.
86	Call having requested call identity has been cleared	The network received a call resume request containing a call identity information element for a call that was cleared while suspended, either by timeout or by the remote user.
88	Incompatible destination	Indicates that an attempt was made to connect to non-ISDN equipment, such as an analog line.

Table 6-7. ISDN Call Status Codes (Continued)

Code	Cause	Definition
91	Invalid transit network specified	The ISDN exchange was asked to route the call through an unrecognized intermediate network.
95	Invalid message, unspecified	An invalid message was received, for an unknown reason. This is usually due to a D-channel error. If this error occurs systematically, report it to your ISDN service provider.
96	Mandatory information element is missing	The equipment received a message that did not include one of the mandatory information elements. This is usually due to a D-channel error. If this error occurs systematically, report it to your ISDN service provider.
97	Message type nonexistent or not implemented	The equipment received a message of a type that is invalid or not supported. This code indicates either a problem with the remote configuration or a problem with the local D channel.
98	Message incompatible with call state or message type nonexistent	The equipment received a message that is not valid in the current call state. Cause 98 is usually due to a D-channel error. If this error occurs systematically, report it to your ISDN service provider.
99	Information element nonexistent or not implemented	The equipment received a message that includes information elements which were not recognized. This is usually due to a D-channel error. If this error occurs systematically, report it to your ISDN service provider.
100	Invalid information element contents	The equipment received a message that includes invalid information in the information element. This is usually due to a D-channel error.
101	Message not compatible with call state	The remote equipment received a message that does not correspond to the current state of the connection. This is usually due to a D-channel error.

Table 6-7. ISDN Call Status Codes (Continued)

Code	Cause	Definition
102	Recovery on timer expiry	A time-out has triggered an error-handling (recovery) procedure. This problem is typically temporary.
111	Protocol error, unspecified	An unspecified D-channel error when no other standard cause applies.
127	Interworking, unspecified	An event occurred within a network that does not provide causes for the action that it takes. The precise problem is unknown.
145	ISDN layer 1 and/or 2 link not established	User needs to check cabling, ISDN adapter status and network connections.
146	ISDN layer 3 connection to the ISDN switch/network inactive	There is either a switch protocol error, or (in the United States or Canada) a SPID assignment problem.
255	ISDN command processing error	The ISDN signaling code has encountered an error processing an ISDN action. ISDN adapter busy-wait and retry.



System Interoperability

The ViewStation EX, ViewStation FX, and VS4000 can work with the following non-Polycom endpoint equipment:

Table A-1. H.320 Endpoints

Manufacturer	Model	Version
Sony	PCS6000	4.1
Tandberg	500 800 1000 2000 6000	B5.1
VCON	Cruiser Media Connect 8000	4.6
VTEL	Galaxy	2.2.0.070

Table A-2. H.323 Endpoints

Manufacturer	Model	Version
Microsoft	NetMeeting	2.1, 3.0, 3.01 ^a
Tandberg	500 800 1000 2500 6000	B5.1
VCON	Cruiser Escort Media Connect 8000	4.6
	ViGO™	5.1
	Falcon	3.0
VTEL	Galaxy	2.2.0.70

a. No application sharing, file transfer, or whiteboarding in versions 3.0 and 3.01

The ViewStation EX, ViewStation FX, and VS4000 can work with the following non-Polycom MCUs:

Table A-3. H.323 MCU Interoperability

Manufacturer	Model	Version
H.320		
Lucent	Multi-Point Conferencing Unit ^a	
H.323		
Ezenia	MCS	1.2.2
	Encounter 3000 ECMS	1.01
Radvision	MCU	2.2.1.0.9d
	viaIP 400 MCU	2.2.265
Whitepine	Meeting Point	5.0

a. chair control, far-end camera control and T.120 do not work in cascaded calls

The ViewStation EX, ViewStation FX, and VS4000 can work with the following non-Polycom gateways and gatekeepers:

Table A-4. Gateway/Gatekeeper Interoperability

Manufacturer	Model	Version
Cisco	MCM Gatekeeper with 3640 router	12.1 build 7
Ezenia	Gatekeeper	1.2.2
	Encounter 3000 Netgate/Gatekeeper	1.0
	Encounter 3000 ECMS Gatekeeper	1.01

Table A-4. Gateway/Gatekeeper Interoperability (Continued)

Manufacturer	Model	Version
Radvision	L2W-323BRI Gateway/Gatekeeper L2W-323PRI Gateway/Gatekeeper	2.2.3.2.5
	MCU Gatekeeper	2.2.1.0.9d
	NGK 200 Gatekeeper	1.0
	T120 Data Collaborator Server	1.07
	ECS/viaIP Gatekeeper	2.0.2.2
Whitepine	Meeting Point Gatekeeper	5.0

The ViewStation EX, ViewStation FX, and VS4000 can work with the following NATs and firewalls:

Table A-5. NAT and Firewall Interoperability

Manufacturer	Version
Cisco Router	12.2 Build 7
Cisco PIX ^a	6.1.2
Linksys	1.40.2
NetGear	3.24
SMC	1.93s

a. Cisco PIX firewall configuration issue: The Cisco document at www.cisco.com/warp/public/707/28.html details a problem regarding accepting data from a system outside the firewall and offers the solution. The solution allows external systems to communicate with those inside the PIX firewall, allowing the videoconference to take place. Please refer to the sections "Allowing Untrusted Hosts Access to Hosts on Your Trusted Network" and "Disabling NAT" of the Cisco document.

B

ViewStation Series Cables

The following tables list cables for systems in the ViewStation family.

Board Room and Custom Room Systems

Table B-1. Cables for VS4000

Use	Description	Length and pinout	Longer version
PC Ethernet	Blue RJ-45	25 ft (7.6 m), Standard	No
Camera, document camera, or monitor	(6) Yellow S-video	25 ft (7.6 m), Standard	50 ft/15.2 m
VCR	Red/white/yellow RCA	8 ft (2.4 m), Standard	No
Microphone pod	Brown RJ-9	10 ft (3 m), Custom	30 ft/9.1 m
ISDN network	Light Blue RJ-45	20 ft (6.1 m), Standard	No
Serial	Violet DB-9	25 ft (7.6 m), Standard	No
Audio device input	Single black RCA	25 ft (7.6 m), Standard	No
monitor	(6) Single yellow RCA	25 ft (7.6 m), Standard	50 ft/15.2 m
IP network	Orange RJ-45	25 ft (7.6 m), Standard	No
Camera control	Yellow 8-pin DIN TO DB-9	25 ft (7.6 m), Custom	50 ft/15.2 m
XGA projector or monitor	XGA - yellow DB-15	30 ft (9.1 m), Standard	No
monitor	Red/white RCA	25 ft (7.6 m), Standard	No
IPOTS	Pink RJ-11	25 ft (7.6 m)	No

Table B-2. Cables for ViewStation EX and ViewStation FX

Use	Description	Length and pinout	Longer version
PC Ethernet	Blue RJ-45	25 ft (7.6 m), Standard	No
IP network	Orange RJ-45	12 ft (3.7 m), Standard	No
Audio device input	Single black RCA	8 ft (2.4 m), Standard	No
Document camera	Yellow S-video	25 ft (7.6 m), Standard	No
Second monitor	Yellow S-video	8 ft (2.4 m), Standard	No
VCR	Red/white/yellow RCA	8 ft (2.4 m), Standard	No
Microphone pod	Brown RJ-9	10 ft (3 m) Custom	30 ft/9.1 m
Monitor	Triple RCA with S-video	6 ft (1.8 m), Standard	No
ISDN network	Light blue RJ-45	20 ft (6.1 m), Standard, keyed	No
XGA projector or monitor For FX only	XGA breakout	1 ft (0.3 m) Custom	No
Serial	Yellow 8-pin DIN to DB-9	10 ft (3 m) Custom	No
Camera or camera control For FX only	Yellow 8-pin DIN to 8-pin DIN/4-pin DIN	50 ft (15.2 m) Standard	100 ft/30.5 m
IPOTS	Pink RJ-11	12 ft (3.7 m)	No

Table B-3. Cables for Upgrades to ViewStation EX, ViewStation FX, and VS4000

Use	Description	Length and pinout	Longer version
Quad BRI network side	(4) Quad BRI - clear RJ-45	20 ft (6.1 m), Standard	No
Quad BRI to ViewStation EX or FX	Light blue to green RJ-45	20 ft (6.1 m), Standard, keyed	No
V.35 module upgrade	No cables are associated with this upgrade kit		
PRI module network side	Quad BRI - Clear RJ-45	20 ft (6.1 m), Standard	No

Table B-4. Cables for ViewStation EX, ViewStation FX, and VS4000 Accessories

Use	Description	Length and pinout	Longer version
Visual Concert FX to PC	VGA, audio, LAN composite cable	5 ft (1.5 m) Custom	No
Visual Concert FX to ViewStation EX, FX or VS4000	RJ-45 TO RJ-45/RJ-9/2-pin Molex	30 ft (9.1 m), standard	50 ft/15.2 m
Visual Concert FX microphone pod	Brown RJ-11 to RJ-9	6 ft (1.8 m), Standard	No
PC TO Visual Concert PC	Brown RJ-9 TO PCMCIA	4 ft (1.2 m), Custom	No

Table B-5. Additional Cables for ViewStation EX, ViewStation FX, and VS4000

Use	Description	Length and pinout	Longer version
V.35 Y-cable	DB-25M to M34 Winchester/RS-366 DB-25M	5 ft (1.5 m) Custom	No
V.35 Cable adapter for ViewStation EX, FX and VS4000	HD-44M to DB-25F	1 ft (0.3 m) Custom	No
V.35 for ViewStation FX and VS4000	Ascend HD-44M to HD-44M	5 ft (1.5 m) Custom	No
V.35 Y-cable for ViewStation FX and VS4000	HD-44M to M34 Winchester/RS-366 DB-25M	5 ft (1.5 m) Custom	No
RS-449 Y-cable	HD-44M to RS-449 DB 37M/RS-366 DB-25M	5 ft (1.5 m) Custom	No

Medium and Large Room Systems

Table B-6. Cables for ViewStation H.323

Use	Description	Length and pinout	Longer version
IPOTS	Pink RJ-11	12 ft (3.7 m)	No
IP network	Orange RJ-45	12 ft (3.7 m), Standard	No
PC Ethernet	Blue RJ-45	25 ft (7.6 m), Standard	No
Audio device input	Black single RCA	8 ft (2.4 m), Standard	No
VCR	Red/white/yellow RCA	8 ft (2.4 m), Standard	No
Second monitor	Yellow S-video	8 ft (2.4m), Standard	No
Document camera	Yellow S-video	25 ft (7.6 m), Standard	No
Microphone pod	Brown RJ-9	30 ft (9.1 m), Custom	No
ISDN network	Green RJ-45	20 ft (6.1 m), Standard	No
Monitor	Triple RCA with S-video	6 ft (1.8 m), Standard	No

Table B-7. Cables for ViewStation MP

Use	Description	Length and pinout	Longer version
IPOTS	Pink RJ-11	12 ft (3.7 m)	No
IP network	Orange RJ-45	12 ft (3.7 m), Standard	No
PC Ethernet	Blue RJ-45	25 ft (7.6 m), Standard	No
Audio device input	Black single RCA	8 ft (2.4 m), Standard	No
VCR	Red/white/yellow RCA	8 ft (2.4 m), Standard	No
Second monitor	Yellow S-video	8 ft (2.4 m), Standard	No
Document camera	Yellow S-video	25 ft (7.6 m), Standard	No
Microphone pod	Brown RJ-9	30 ft (9.1 m), Custom	No
ISDN network	Green RJ-45	20 ft (6.1 m), Standard	No
Monitor	Triple RCA with S-video	6 ft (1.8 m), Standard	No
Network interface	(4) Quad BRI - clear RJ-45	20 ft (6.1 m), Standard	No

Table B-8. Cables for ViewStation MP DCP

Use	Description	Length and pinout	Longer version
IPOTS	Pink RJ-11	12 ft (3.7 m)	No
IP network	Orange RJ-45	12 ft (3.7 m), Standard	No
PC Ethernet	Blue RJ-45	25 ft (7.6 m), Standard	No
Audio device input	Black single RCA	8 ft (2.4 m), Standard	No
VCR	Red/white/yellow RCA	8 ft (2.4 m), Standard	No
Second monitor	Yellow S-Video	8 ft (2.4 m), Standard	No
Document camera	Yellow S-Video	25 ft (7.6 m), Standard	No
Microphone pod	Brown R-J9	30 ft (9.1 m), Custom	No
ISDN network	Green RJ-45	20 ft (6.1 m), Standard	No
Monitor	Triple RCA with S-video	6 ft (1.8 m), Standard	No

Table B-8. Cables for ViewStation MP DCP (Continued)

Use	Description	Length and pinout	Longer version
Network interface	(4) DCP- clear RJ-45	20 ft (6.1 m), Standard	No
DCP interface only	DCP Green/white RJ-45	20 ft (6.1 m), Standard, keyed	No

Table B-9. Cables for Upgrading ViewStation Models (Except FX)

Use	Description	Length and pinout	Longer version
Quad BRI network side	(4) Quad BRI - Clear RJ-45	20 ft (6.1 m), Standard	No
V.35 to MP, network	(4) DCP - Clear RJ-45	20 ft (6.1 m), Standard	No
MP upgrade kit	No cables associated with this kit		
V.35 module upgrade kit	No cables associated with this kit		
DCP Module, network side	(4) DCP- clear RJ-45	20 ft (6.1 m), Standard	No
DCP interface only	DCP green/white RJ-45	20 ft (6.1 m), Standard, keyed	No

Small Room Systems

Table B-10. Cables for ViewStation SP 128

Use	Description	Length and pinout	Longer version
IP network	Orange RJ-45	12 ft (3.7 m), standard	No
Microphone pod	Brown RJ-9	30 ft (9.1 m), standard	No
ISDN network	Green RJ-45	20 ft (6.1 m), standard	No
Monitor	Triple RCA with S-video	6 ft (1.8 m), standard	No

Table B-11. Cables for ViewStation 128

Use	Description	Length and pinout	Longer version
IPOTS	Pink RJ-11	12 ft (3.7 m)	No
IP Network	Orange RJ-45	12 ft (3.7 m), standard	No
PC Ethernet	Blue RJ-45	25 ft (7.6 m), standard	No
Audio device input	Black single RCA	8 ft (2.4 m), standard	No
VCR	Red/white/yellow RCA	8 ft (2.4 m), standard	No
Second monitor	Yellow S-video	8 ft (2.4 m), standard	No
Document camera	Yellow S-video	25 ft (7.6 m), standard	No
Microphone pod	Brown RJ-9	30 ft (9.1 m), Custom	No
ISDN network	Green RJ-45	20 ft (6.1 m), standard	No
Monitor	Triple RCA with S-video	6 ft (1.8 m), standard	No

Table B-12. Cables for ViewStation SP 384

Use	Description	Length and pinout	Longer version
IP network	Orange RJ-45	12 ft (3.7 m), Standard	No
Microphone pod	Brown RJ-9	30 ft (9.1 m), Custom	No
ISDN network	Green RJ-45	20 ft (6.1 m), Standard	No
Monitor	Triple RCA with S-video	6 ft (1.8 m), Standard	No

Safety and Legal Notices

Important Safeguards

Read and understand the following instructions before using any equipment described in this manual:

- Close supervision is necessary when the system is used by or near children. Do not leave unattended while in use.
- Only use electrical extension cords with a current rating at least equal to that of the system.
- Always disconnect the system from power before cleaning and servicing and when not in use.
- Do not spray liquids directly onto the system when cleaning. Always apply the liquid first to a static free cloth.
- Do not immerse the system in any liquid or place any liquids on it.
- Do not disassemble this system (except as instructed in the manufacturer's instructions). To reduce the risk of shock and to maintain the warranty on the system, a qualified technician must perform service or repair work.
- Connect this appliance to a grounded outlet.
- In case of lightning storms, disconnect the telephone line cord from the system, and only connect the system to surge protected power outlets.
- Keep ventilation openings free of any obstructions.
- SAVE THESE INSTRUCTIONS.

License Restrictions

THE SOFTWARE PROGRAMS CONTAINED OR DESCRIBED HEREIN ARE CONFIDENTIAL INFORMATION AND PROPRIETARY PRODUCTS OF POLYCOM, INC. OR ITS LICENSORS.

Buyer shall not sublicense or otherwise distribute any of the Subject Programs except to End Users and/or resellers who have entered into a Sublicense Agreement. For purposes of this Agreement a "Sublicense Agreement" shall mean a written license agreement between the Buyer and its purchaser, or, in the case of any sale by Buyer to a reseller, between such reseller and the End User, that is either 1) signed by the End User or 2) included with the Documentation, in such a manner that the End User reasonably indicates its acceptance of the Sublicense Agreement by turning on and using the Computer Equipment. Polycom, Inc. shall include so-called "break the seal software licenses" with the Documentation, and Buyer shall not remove or alter any such Sublicense Agreements or any notifications or warning stickers relating thereto. Buyer shall not waive, amend, or otherwise modify any Sublicense Agreement without Polycom's prior consent.

Title to all Subject Programs shall at all times remain and vest solely with Polycom, Inc. and its licensors. Buyer acknowledges Polycom's claim that the Subject Programs are its trade secret and confidential property, and shall treat them as such. Buyer will not attempt to disassemble, decompile, reverse-engineer or otherwise endeavor to discover or disclose the methods and concepts embodied in the Subject Programs. Except as expressly allowed under this Agreement, the Buyer shall not copy, modify, transcribe, store, translate, sell, lease, or otherwise transfer or distribute any of the Subject Programs in whole or in part, without prior authorization, in writing, from Polycom, Inc.. Buyer shall not remove or destroy any copyright, patent, trademark or other proprietary mark or notice on Computer Equipment, and shall reproduce any such marks on any copies of Subject Programs that it makes hereunder.

You shall not, and shall not allow, any third party to 1) decompile, disassemble, or otherwise reverse-engineer or attempt to reconstruct or discover any source code or underlying ideas or algorithms of the software by any means whatsoever or 2) remove any product.

Limitation of Remedies and Damages

Polycom, Inc., its agents, employees, suppliers, dealers and other authorized representatives shall not be responsible or liable with respect to the product or any other subject matter related thereto under any contract, negligence, strict liability or other theory for any indirect, incidental, or consequential damages, including, but not limited to loss of information, business, or profits.

The law of certain states or nations does not permit limitation or exclusion of implied warranties and consequential damages, so the above limitations, disclaimers, or exclusion may not apply to you. This warranty gives you special legal rights. You may also have other rights that vary by state and nation.

A

- acoustics 73
- address
 - E.164 56
 - H.323 (IP) 56
- administration plan 58
- Adtran Atlas 800 Plus E1 module 82
- ARENA API 19, 20
- audio codecs 17
- audio quality 17, 73

B

- bandwidth
 - allocation policy 58
 - PRI E1 26
 - PRI T1 26
 - requirements
 - calculating 50
- browser, see Web browser 19

C

- cable
 - adapter
 - coaxial, for ViewStation FX/VS4000 PRI 83
 - ViewStation FX/VS4000 V.35/RS-449 31
 - Ascend HD-44M to HD-44M Y 36
 - diagram 36
 - pinout 36
 - crossover, network interface module to PBX 80, 83
 - extension
 - ViewStation FX/VS4000 to network interface module 83

- for direct connect 85
- HD-44M to DB-25M/RS-366 and DB-37M/RS-449/422 85
- HD-44M to DB-25M/RS-366 and M34 Winchester V.35 85
- HD-44M to HD-44M 85
- HD-44M to RS-366 Y 32, 33
 - diagram 32
 - pinout 33
- HD-44M to RS-449/RS-422 Y 34, 35
 - diagram 34
 - pinout 35
- not supported 23, 29
- PRI to network 84
- Quad BRI to network 24
- RS-232 for ViewStation FX
 - diagram and pinout 20
- RS-232 for VS4000
 - diagram and pinout 21
- V.35/RS-449
 - for encryption equipment 44
- ViewStation FX/VS4000 Quad BRI to network
 - diagram and pinout 24
- ViewStation FX/VS4000 to network interface module 23, 83, 84
 - diagram and pinout 23

- call
 - cascading 18
 - multipoint 18, 98, 99, 100, 101, 102, 103, 104, 105
 - point-to-point 98, 99, 100, 101, 102, 103, 104
 - test 96
- call blocking 27
- call routing 57
- caller ID 27
- camera 16
- camera presets 16

- cascading 18
- channel restarts, Adtran Atlas 800 Plus E1 module 82
- channel selection, ViewStation FX/VS4000 PRI 30
- channel service unit, see CSU 82
- clock
 - source
 - PRI 26, 83
 - V.35/RS-449 32
- closed captioning 19
- codecs
 - video 14
- codecs, audio 17
- collaboration tools 19
- common speeds, V.35 31
- connection speed
 - PRI E1 26
 - PRI T1 26
- continuous presence mode 98, 99, 100
- conversion tool 19
- CSU, for ViewStation FX/VS4000 PRI 82

D

- dedicated T1 or E1 line 30
- deployment process, defined 78
- DHCP 92, 93, 95
- diagnostics 113
 - ISDN 114, 115, 116, 117, 118, 119
 - ViewStation FX/VS4000
 - PRI 27, 28
 - Quad BRI 22
 - V.35/RS-449 31, 32
- dial plan 57
- discussion mode
 - ViewStation FX/VS4000
 - four monitors 103, 104
 - single monitor 98, 99
 - three monitors 101, 102, 103
 - two monitors 100, 101
- display

- ViewStation FX/VS4000
 - four monitors 103, 104, 105
 - single monitor 98, 99
 - three monitors 101, 102, 103
 - two monitors 99, 100, 101

E

- E.164 address 56
- E1 line, dedicated 30
- error codes, ISDN 114, 115, 116, 117, 118, 119
- error correction 15

F

- fail-over management 57
- fault isolation 113
 - ISDN 114, 115, 116, 117, 118, 119
 - ViewStation FX/VS4000
 - PRI 27, 28
 - Quad BRI 22
 - V.35/RS-449 31, 32
 - ViewStation FX/VS4000 PRI 28
- file conversion tool 19
- firewall interoperability 124
- frame rate 15
- full-screen mode
 - ViewStation FX/VS4000
 - four monitors 103, 104, 105
 - single monitor 98, 99
 - three monitors 101, 102, 103
 - two monitors 100, 101

G

- gatekeeper 57
 - assignment 57
- gateway 57
 - assignment 57
- gateway/gatekeeper interoperability 123
- graphics resolution 15

GUI, ViewStation FX/VS4000 19

I

indicator lamps, see specific equipment models 22

internal telephone system, see PBX 22

interoperability 121, 122, 123, 124

IP address 92

DCHP 92, 93, 94, 95

NAT 89, 90

IP precedence 50

ISDN connection 25

ISDN error codes 114, 115, 116, 117, 118, 119

ISDN network interface modules 12

ITU-T standards 14

J

jitter 50

L

languages, ViewStation FX/VS4000 19

latency 50

LEDs, see specific equipment models 22

lighting 72

M

MCU interoperability 123

media players 18

microphone pods

for ViewStation FX/VS4000 17

placement 17, 73

multipoint call 98, 99, 100, 101, 102, 103, 104, 105

multipoint calls 18

N

NAT 89

configuring 90

NAT interoperability 124

network

policy 58

network address translation, see NAT 89

network interface module, see specific endpoint models 22

network interface modules, ISDN 12

network termination device, see NT-1 device 22

NFAS (non-facility-associated signaling) 27

NT-1 device 22, 24, 81

required if no PBX 80

NT-1 device settings 24

P

packet loss 50

PBX 22, 80, 83

pcPresent 19

performance issues 51, 72, 81, 82, 92, 94, 113, 114, 115, 116, 117, 118, 119, 124

picture quality 72

plan

administration 58

dial 57

zone 57

point-to-point call 98, 99, 100, 101, 102, 103, 104

policy

bandwidth allocation 58

network 58

Polycom Office

definition 45

interoperability with non-Polycom equipment 121, 122, 123, 124

Polycom Video Error Concealment (PVEC) 15

PolycomSNAP 19

- power supply, for ViewStation FX/VS4000
 - PRI 81, 82
- power supply, PRI 84
- PowerPoint file conversion tool 19
- presentation mode
 - ViewStation FX/VS4000
 - four monitors 103, 104, 105
 - single monitor 98, 99
 - three monitors 101, 102
 - two monitors 100
- presentation tools 19
- preset camera position, see camera presets
 - 16
- PVEC
 - defined 15

Q

- QoS (quality of service) 50
- quality
 - audio 17, 73
 - video 72

R

- remote control, ViewStation FX/VS4000 19
- resolution
 - graphic 15
 - video 15
- room lighting 72
- RS-232
 - command line interface 107, 108
 - ViewStation FX/VS4000
 - control mode 105, 106
 - flow control 106
 - pass-thru mode 105, 106

S

- screen capture tool 19
- security 72
- settings

- NT-1 device 24
- site recommendations 72, 73
- software update
 - ViewStation FX/VS4000
 - PRI 28
 - Quad BRI 25
- speakerphone 18
- SPID allocation 25
- standards, ITU-T 14
- streaming, see video streaming 18
- system requirements
 - PC connected to ViewStation FX/VS4000 (Ethernet) 91

T

- T1 line, dedicated 30
- TCP/IP 95
- test calls 96
- tools
 - collaboration 19
 - file conversion 19
 - presentation 19
 - screen capture 19
- touchscreen 19
- tracking
 - to presets 16
 - voice 16
- traffic management 57

U

- user administration 58

V

- video
 - streaming 18
- video codecs 14
- video error concealment 15
- video resolution 15

- video signal format 14
- ViewStation FX
 - cable, RS-232 20
 - defined 12
- ViewStation FX/VS4000
 - audio specifications 16, 17
 - cable
 - extension to network interface module 83
 - Quad BRI to network 24
 - to network interface module 23, 83, 84
 - configuration 92
 - connecting to PC Ethernet port 91
 - DHCP server 94
 - electrical specifications 12
 - four monitors 103, 104, 105
 - frame rate 15
 - graphics resolution 15
 - microphone placement 17
 - microphone pod specifications 17
 - multipoint calling 18
 - network interface modules 13
 - PRI 26, 27, 28, 29, 30, 81
 - Adtran Atlas 800 Plus 82
 - channel selection 30
 - CSU 82
 - CSU configuration 88
 - external CSU 88
 - external power supply 26, 81, 82
 - indicator lamps 27, 28
 - installation 84
 - internal CSU 88
 - power supply 84
 - PRI E1 27
 - channel number to timeslot mapping 30
 - PRI network interface module defined 12
 - PRI T1 27
 - Quad BRI 22, 23, 24, 25
 - indicator lamps 22
 - installation 80
 - installing 81
 - Quad BRI network interface module, defined 12
 - RS-232
 - command line interface 107, 108
 - configuration 107
 - control mode 105, 106
 - flow control 106
 - pass-thru mode 105, 106
 - RS-232 interface 20
 - single monitor 98, 99
 - three monitors 101, 102
 - two monitors 99, 100, 101
 - user interface 19
 - V.35/RS-449 31, 32, 33, 34, 35, 36, 38, 39, 40, 41, 42, 43, 44
 - Crypto Resync option 44
 - cryptographic resynchronization 40, 41, 42, 43, 44
 - indicator lamps 31, 32
 - installation 86
 - interface signals 38
 - state machine 39, 40, 41, 42, 43
 - V.35/RS-449 network interface module defined 12
 - V.35/RS-449 not backward-compatible 31
 - video resolution 15
 - video signal formats 15
 - video streaming 18
- Visual Concert
 - display 98, 99, 100, 101, 102, 104
- Visual Concert products 19
- voice tracking 16
- VS4000
 - cable
 - RS-232 21
 - camera 16
 - defined 12

W

Web browser requirements 19, 91

Z

zone plan 57