



VSX™ 7000 Administrator's Guide



Trademark Information

Polycom® and the Polycom logo design are registered trademarks of Polycom, Inc., and Siren™ 14, Pro-Motion™, People+Content™, and VSX™ are trademarks of Polycom, Inc. in the United States and various other countries. All other trademarks are the property of their respective owners.

Patent Information

The accompanying product is protected by one or more U.S. and foreign patents and patents pending held by Polycom, Inc.

© 2003 Polycom, Inc. All rights reserved.

Polycom Inc.
4750 Willow Road
Pleasanton, CA 94588-2708
USA

No part of this document may be reproduced or transmitted in any form or by any means, electronic or mechanical, for any purpose, without the express written permission of Polycom, Inc. Under the law, reproducing includes translating into another language or format.

As between the parties, Polycom, Inc. retains title to, and ownership of, all proprietary rights with respect to the software contained within its products. The software is protected by United States copyright laws and international treaty provision. Therefore, you must treat the software like any other copyrighted material (e.g. a book or sound recording).

Every effort has been made to ensure that the information in this manual is accurate. Polycom, Inc. is not responsible for printing or clerical errors. Information in this document is subject to change without notice.

About this Guide

This guide is for installers and administrators and contains everything you need to know to:

- Install the VSX system,
- Configure the system for use in your network environment,
- Customize the system workspace for easy and efficient use, and
- Help users in your organization learn to use the system.

For information about using the system to place calls and do other conferencing tasks, see the *VSX Series Getting Started Guide*. This document is available on the documentation CD and at www.polycom.com/videodocumentation.

For support or service, please contact your Polycom distributor or go to Polycom Support at www.polycom.com/support.

Polycom recommends that you record the serial number of your VSX system here for future reference. The serial number for the system is printed on the unit.

System Serial Number: _____

Contents

Chapter 1 - Introducing the VSX System

Key Features	10
Breakthrough Video Quality	10
Industry-Leading Audio Quality	10
Easier Data Sharing with People+Content	10
Enhanced User Experience	11
Easy Installation	12
Remote Management	12
Primary System Components	13
Options Available with the VSX System	14
Other Equipment You Can Use with the VSX System	14

Chapter 2 - Setting Up the Equipment

Pre-Installation Checklists	16
Network Connectivity Information Checklist	16
ISDN Network Hardware Checklist	17
Room Setup Assessment Checklist	18
Setting Up the System	19
Installing the Network Interface Module	19
Positioning the System	20
Connecting the System	22
Connecting Additional Equipment	25
Additional microphone pod	25
Visual Concert™ VSX™	26
Additional monitor or projector	26
Document camera or other additional camera	27
VCR or DVD — To Play	28
VCR or DVD — To Record	28

Chapter 3 - Configuring Network Use

Accessing the System Screens	30
Configuring with the Setup Wizard	30
Configuring LAN Properties	31
Configuring IP Network Support	33
Specifying H.323 Settings	33
Configuring the System to Use a Gatekeeper	34
Configuring the System to Use a Gateway	35
Specifying Quality of Service	36
Configuring the System for Use with a Firewall or NAT	37
Configuring ISDN Support	39
Configuring the Quad BRI network interface	39
Choosing Call Quality Options	40
Configuring Global Services	41
Configuring the Directory Server Settings	41

Configuring the System for a Private Network	42
Setting the Dialing Rules	43
Viewing the Management Servers List	45
Requiring an Account Number for Calls	45
Adding My Information	46
Requesting Technical Support from the GMS Administrator	47
Placing a Test Call	48
Checking System Status	49
Keeping your Software Current	49

Chapter 4 - Designing the User Experience

Managing User Access to Settings and Features	52
Setting the Admin Password	53
Letting Users Customize the Workspace	54
Limiting What Users Can Do With the System	55
Using the System for Specialized Applications	55
Designing Video and Audio Behaviors	56
Configuring Camera Settings and Video Quality Options	57
Configuring TV Monitors	58
Using Dual Monitor Emulation	59
Using a High-Resolution Display to Show Content	60
Configuring Audio Settings	61
Customizing the Workspace Appearance	63
Designing the Home screen	64
Adding Sites	67
Adding On-screen Instructions	68
Using Marquee Text	68
Using Screen Saver Text	68
Changing Color Schemes	69
Customizing Camera Names and Icons	69
Setting Ring Tones and Alert Tones	69
Designing General System Behaviors	70
Configuring System Settings	70
Configuring Multipoint Calling	72
Setting Call Quality Preferences	72
Setting the Call Answering Mode	73
Setting Passwords and Security Options	73
Setting Date, Time, and Location	74
Helping Users Get Started	75

Chapter 5 - System Usage and Statistics

Call Summary	78
Call Statistics	79
Call Status	80
Recent Calls	81
Call Detail Report	82
Information in the CDR	83
Call Detail Report (CDR) Archives	85

Chapter 6 - Diagnostics and General Troubleshooting

Sending a Message	88
System Screens Quick Reference	88
Diagnostic Screens	89
System Status Tools	90
The System Status screen	90
The Call Summary screen	90
Call Statistics Tools	91
The Call Status screen	91
The Call Statistics screens	91
Network Tools	92
The Near End Loop test	92
The PING Screen	92
Video Tool	93
Audio Tools	93
The Speaker Test screen	93
The Audio Meter screen	94
The Reset System Screen	95
General Troubleshooting	96
Critical Problems	96
Severe Problems	98
Minor Issues	101
Normal System Behaviors	104
How to Contact Technical Support	105
By Telephone	105
By Internet	105

Appendix Appendix - 1

Graphics Displays	1
Multipoint Dialing Speed Information	2
Cable Descriptions	2
Cable Drawings	4
Q.850 Cause Codes	8

Safety and Legal Notices Safety and Legal Notices - 1

Index Index - 1

1

Introducing the VSX System

The VSX videoconferencing system is a state-of-the-art visual collaboration tool. With crisp, clean video and crystal-clear sound, the VSX system provides natural videoconferencing interaction through the most advanced video communications technology.

When you use the VSX system for meetings, you can exchange ideas and share documents with people anywhere in the world, as if they were all in the room with you. Everyone's productivity increases, without any travel required.



Key Features

Breakthrough Video Quality

- ❑ **Best for low bandwidth calls** — The newly-supported H.264 standard provides twice the video quality of H.263 at lower line rates.
- ❑ **Best for high bandwidth calls** — Calls at 512 Kbps and higher use Polycom's own standards-based Pro-Motion™ 50/60 fields per second video for the best video available.

Industry-Leading Audio Quality

- ❑ **State-of-the-art audio quality** — The VSX system offers a 14 kHz frequency response (beating the current industry standard of 7 kHz) and the system also supports the industry-standard audio codecs.
- ❑ **Higher quality speakers** — The built-in mid-range speaker and separate subwoofer deliver higher quality audio than typical built-in TV speakers.
- ❑ **Better sound for meetings and media** — The subwoofer adds depth and richness to the audio, providing a stronger, more natural sound for day-to-day meetings, while adding clarity and punch to calls with multimedia content.
- ❑ **Better sound in large rooms** — Improve the audio pick-up in larger rooms by connecting up to three digital microphone pods.

Easier Data Sharing with People+Content

- ❑ **See more with single-monitor systems** — Systems with one monitor can now use Dual Monitor Emulation (split-screen viewing) to see both people and content at the same time. Dual Monitor Emulation was specially designed for systems with plasma displays, but it can also be used with any other type of display.
- ❑ **High resolution data collaboration** — You can use the optional Visual Concert VSX to connect computer to provide shared content and a VGA monitor or projector for viewing shared content at high resolution. The Visual Concert VSX can also provide LAN connectivity for up to 3 computers, including the one sharing content.

Enhanced User Experience

- ❑ **Customizable Home screen** — Customize the Home screen to support all of your users:
 - **New or infrequent users** — Offer just a few options, so users need little or no training.
 - **Advanced users** — Provide a wide range of videoconferencing features.
- ❑ **Customizable look and feel** — Set up the workspace to suit your environment.
 - **Screen colors and ring tones** — Change the colors and ring tones to suit the décor and environment.
 - **Camera names and icons** — Name each video source and assign it an industry-specific icon so users can easily identify it during meetings.
 - **Support for ViewStation users** — Configure the workspace with the classic ViewStation look to build on users' experience with ViewStation videoconferencing systems.
- ❑ **New remote control design** — Navigate through the configuration screens and place calls easily using the new remote control.
 - **Enter text** — Press the number buttons to enter text using the method commonly used with cell phones.
 - **Go Back** — Navigate back through the menus using the Back button.
 - **Go Home** — Return to the Place a Call screen with one button press.
 - **Enter a dot** — Enter addresses and names that include dots using the Dot button.
 - **Color-coded buttons** — Buttons for related features are color coded to help you find them quickly.
- ❑ **Multipoint calling** — You can place IP, ISDN, and mixed calls that include up to three other sites at once using the internal multipoint option.
- ❑ **More ways to use the Directory** — Find information in the Directory using the method you find most convenient.
 - **Assign entries to categories** — Sort your local directory by department or category.
 - **Define group entries** — Save details of multiple sites in one Directory entry to make it easy to place a multipoint call.
 - **Search by name** — Quickly find people by entering the first, middle, or last name.

- **Find others and let them find you** — Register with the Global Directory Server and make it easy to call other registered systems and just as easy for the other registered systems to call you.
- **Access the Global Directory any time** — The system automatically copies the Global Directory to your system periodically, so entries are always available.

Easy Installation









- Simple setup** — The set-top unit has a compact and sleek new design that is easy to install. The unit fits conveniently on top of a traditional monitor.
- Additional monitor** — Add an optional second monitor for more flexibility in what you present to call participants at your site.
- IP or ISDN calling** — The VSX system has a built-in 10/100 Mb Ethernet port for IP calls. Add the optional Quad BRI network interface to make calls over your ISDN telephone lines.
- Additional camera** — Add an auxiliary camera for more flexibility in what you present to participants at the far site.
- Easy configuration wizard** — The system setup wizard detects your network connections and guides you through configuring the system to work on an IP network or an ISDN network.
- Auto-sensing power supply** — The system automatically adjusts for line voltages from 90 to 264 V and line frequencies from 47 to 63 Hz.

Remote Management

- Language independence** — Use the VSX web interface in your language to configure and administer systems running in any other language.
- Secure remote management** — The local administrator's password on the system prevents users from changing system configuration while allowing you to manage the system remotely.
- Remote system configuration** — Run the system setup wizard from your web browser to get the system up and running remotely.
- Call Detail Reports** — Access the system's call history from the VSX web interface. You can download the data to a spreadsheet application for sorting and formatting.

Primary System Components

The VSX system includes the following components:

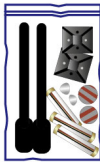
Name	Component	Description
VSX 7000		The VSX 7000 set-top provides cutting-edge videoconferencing technology in a sleek design.
Subwoofer and power		The subwoofer provides additional depth to the sound, creating a high-quality sonic space comparable to a home theater system.
Microphone pod		The microphone pod provides audio input to the VSX 7000 set-top.
Remote Control		Configure and operate the system with the remote control.
LAN cable		Connect the system to the IP network with the LAN cable.
S-Video cable		Connect a monitor with the S-Video cable.
Conference link cable		Connect the microphone pod or a Visual Concert VSX data collaboration unit with the conference link cable.
Documentation		Read Me First QuickStart for equipment setup VSX Documentation Library on CD
Hardware kit		The hardware kit includes: <ul style="list-style-type: none"> • Reusable cable ties • Cable tie mounts • Disks of hook-and-loop material • Vinyl feet • Batteries for the remote control

Options Available with the VSX System

You can add a variety of options to your VSX system. For more information, see your Polycom distributor.

- Quad BRI network interface module** — Allows you to connect to an ISDN network using up to four BRI lines.
- Visual Concert VSX** — Lets you share files from your computer during calls, provides LAN connectivity for up to three systems, and lets you connect a projector or a VGA monitor, even when a second monitor is connected.
- Additional microphone pods** — Allow the system to pick up voices from a larger area.
- PowerCam or other additional camera** — Gives you additional control over what you show to others in the call by adding a document camera or other S-video device.
- Additional monitor or projector capability** — Gives you more flexibility in how you view calls. For example, it allows you to view the person you call at the same time as a presentation.

Other Equipment You Can Use with the VSX System

In addition to the accessories that come with your system, you can connect your choice of the following equipment:

- DVD or VCR** — Lets you record your videoconferences or play recorded material during a call. You can also connect two DVDs or VCRs to play material and record the conference at the same time.
- External audio system** — Lets you enhance the sound quality for calls in large rooms.

2

Setting Up the Equipment

This chapter is for installers of the VSX system.

The chapter has checklists to help you prepare the site, including network connectivity, required network hardware, and room assessment. It describes how to set up the system with the required components and optional equipment.

What's in this Chapter?	Page
Pre-Installation Checklists	16
Setting Up the System	19
Connecting Additional Equipment	25

Pre-Installation Checklists

The checklists in this section help you to ensure that you are ready to install the system.

Refer to *Preparing Your Network for Collaboration*, available at www.polycom.com/videodocumentation, for network configuration checklists.

Network Connectivity Information Checklist

Collect this information before you begin installing the system:

- IP address — to be provided by your Internet Service Provider or system administrator.
- System name — to be provided by the system administrator.
- Gatekeeper address — to be provided by your IP Network Service Provider or system administrator.
- Firewall information — to be provided by your IP Network Service Provider or system administrator.
- ISDN address (for BRI capability) — to be provided by your ISDN Network Service Provider.
- SPIDs (North America only) — to be provided by your ISDN Network Service Provider.
- ISDN switch protocols — to be provided by your ISDN Network Service Provider.

ISDN Network Hardware Checklist

You will need the following network hardware if you purchased the Quad BRI network interface module:

- Quad BRI network interface module with cables
- NT-1 device, if the system will not be connected to a PBX network that provides an S/T interface
- Up to 4 BRI lines that will not be shared with other equipment



Do not use an NT-1 device if you connect the system to a PBX that provides an S/T interface.

Room Setup Assessment Checklist

When you select a room for the system, consider the following factors:

Factor	For best results
Access to required connections	<p>Ensure that the equipment will be within 6 feet (1.8 m) of power and network connections.</p> <p>Ensure that cables are routed in a way that does not inconvenience people who use the room.</p>
Room lighting	<p>Ensure that the camera will normally point toward an area that is well-lit but not exceptionally bright. Lighting should be diffuse to prevent harsh shadows.</p> <p>If there is a window in the room, ensure that the camera does not normally point toward it. Backlighting makes the speaker appear in silhouette.</p>
Room color and décor	<p>The camera will perform best if the room furnishings are medium to dark in color and do not have polished or reflective surfaces.</p> <p>Ensure that the camera normally points toward an area that is of a medium shade and does not contain detailed, patterned, or brightly-colored elements. For example, a blue or gray wall provides a more effective backdrop than a bright painting.</p> <p>To prevent autofocus problems, place an object somewhere near the center of the camera's default position.</p>
Items in camera range	<p>Ensure that no confidential material can be inadvertently disclosed to callers. For example, ensure that white boards in the conference room are not used for engineering sketches.</p>
Acoustics and background noise	<p>Ensure that there is no audible echo in the room where the camera and microphone(s) will be installed. Carpeting, drapery, and upholstered furniture all help to reduce echo problems. Non-rectangular rooms have less echo than standard conference rooms.</p>
Microphone placement	<p>Place the microphone pod between the monitor and the participant closest to the monitor. If you use additional microphone pods, ensure that they are at least 6 feet (1.8 m) apart.</p>

Setting Up the System

The tasks involved in setting up the system are:

- Installing the optional network interface module in the equipment,
- Positioning the equipment,
- Connecting the required peripherals, and
- Connecting optional peripherals.

Installing the Network Interface Module

If you received a network interface module with the system, you may find it convenient to install it before positioning the system.

To install the network interface module in the back of the VSX 7000 subwoofer:

1. Loosen the captive screws holding the cover plate in place, and remove it.
2. Slide the network interface module into the opening, and press firmly to seat the connector.
3. Tighten the captive screws to secure the network interface module in the subwoofer.

If your ISDN network requires additional equipment such as an NT-1 device, ensure that it is available, along with all cables required.

Positioning the System

Before you connect the cables, place the system and its peripherals according to the planned room layout.

To position the system:

1. Place the main monitor so that everyone in the room will be able to see it easily.



If the monitor's chassis slopes back sharply, you may need to install feet on the bottom of the system to stabilize it. The hardware kit you received with the unit includes a pair of feet.

2. Install the feet on the VSX 7000 set-top, if necessary.

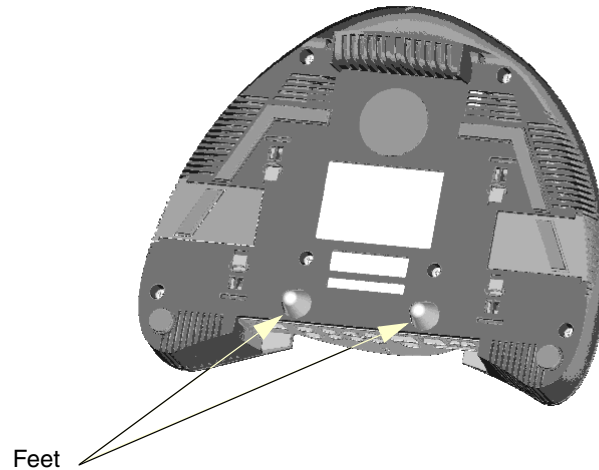

3. Place the VSX 7000 set-top on top of the monitor, or as close to it as possible. Ensure that the set-top lip overlaps the monitor or other surface.



Be sure to remove the packaging collar from around the camera before powering on the system.

4. Place the subwoofer directly below the main monitor if possible.



If you install the system in a cabinet, ensure that the subwoofer is not enclosed behind a solid door. Placing any solid object in front of the subwoofer interferes with the sound.

5. For the best audio, place the microphone pod:
 - on a flat surface away from obstructions,
 - between the monitor and the seats closest to the monitor, and
 - at least 3 ft. (0.9 m) from the system and subwoofer to prevent audio feedback.

If you install more than one microphone pod, ensure that all microphone pods are at least 6 feet (1.8 m) apart.



The microphone pod has two identical receptacles for cables. You can connect the conference link cable to either connector.

Connecting the System

The following figure identifies which ports to use to connect the required equipment to the VSX system.

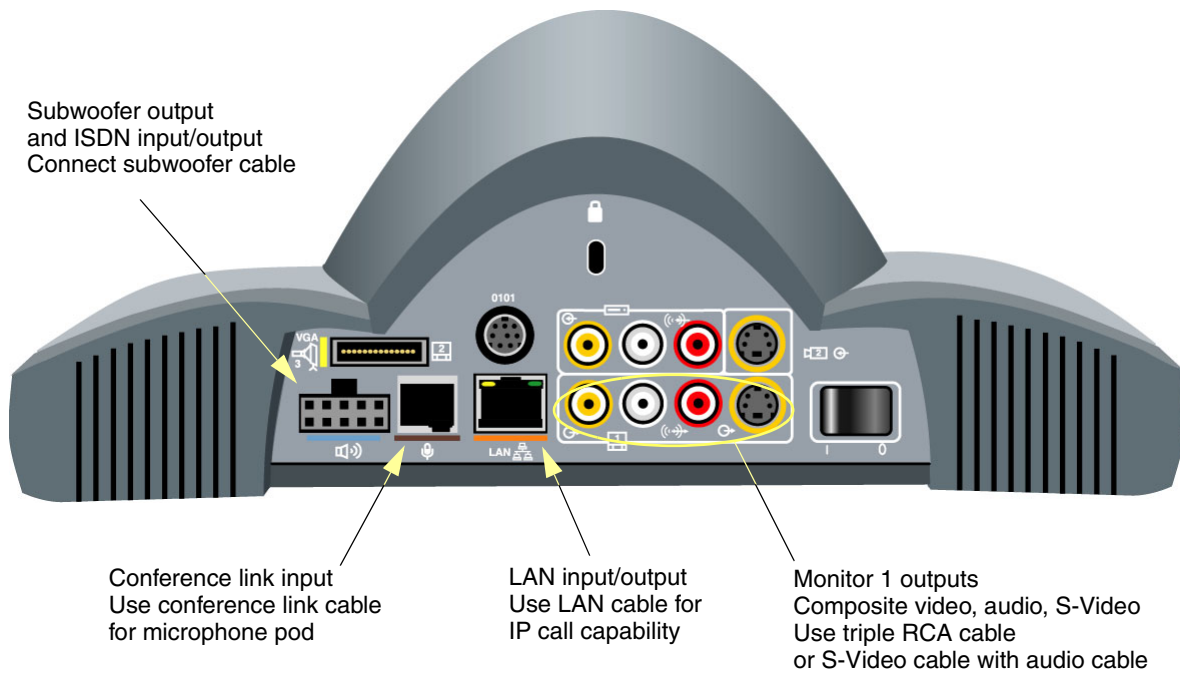

To connect the VSX system:

1. Connect the monitor to the Monitor 1 S-Video or composite video output. This may be an NTSC or PAL monitor, depending on your system.



S-Video provides superior video quality, and is strongly recommended if the system is to be configured to display Asian fonts.

2. Connect the conference link cable to the conference link connector and the microphone pod, with the cable's ferrite bead at the end connected to the system.

You may connect two additional microphones, or you may connect a Visual Concert VSX data collaboration unit and a second microphone. You may connect these devices in any order.

3. Connect the system to the LAN using the LAN cable.



If you set up the VSX system as ISDN-only, it does not require a LAN connection to operate; however, you must connect the system to a LAN to use the Global Directory Server or VSX web interface.

4. If you installed a Quad BRI network interface module, connect it to the appropriate ISDN network using the supplied cable or cables.

If you connect more than one BRI line, connect port 1 of the network interface module to the line with the first ISDN number in the assigned range; connect the other ports in ascending order.

For example, if you use BRI lines 555-1212 through 555-1215, connect port 1 to 555-1212, line 2 to 555-1213, and so on.

The following figure provides details for cabling the Quad BRI network interface module.

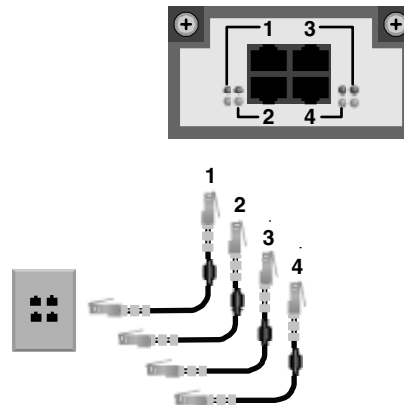

5. To prevent cable entanglement, wrap the enclosed cable ties around the cables.
6. Put the batteries in the remote control.
7. Connect the subwoofer to the system.



If you need to connect additional equipment, skip the next step and go to [Connecting Additional Equipment on page 25](#).

8. Ensure that the system's power switch is off, and connect the subwoofer's power cord to the power outlet.

If you do not plan to connect additional equipment, please go to [Configuring Network Use on page 29](#).

Connecting Additional Equipment

The following figure identifies which ports to use to connect additional equipment to the VSX system.

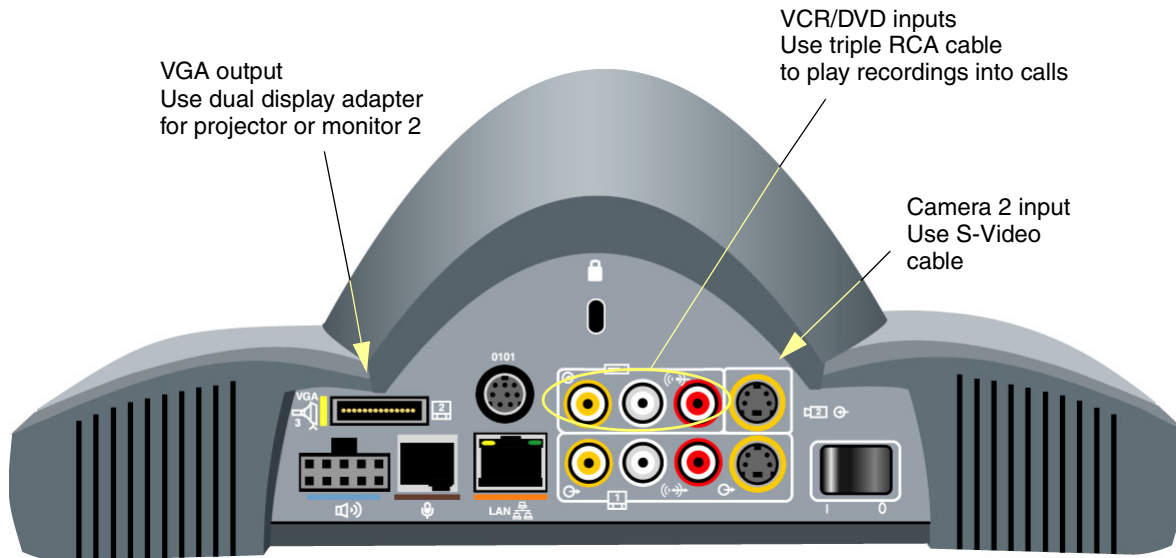

Before you connect additional equipment to the VSX system:

1. Ensure that the system is switched off.
2. Ensure that the subwoofer's power cord is not connected to a power outlet.

Additional microphone pod

1. Connect a conference link cable to the available connector on the microphone pod, or to the available conference link connector on the bottom of the Visual Concert VSX.
2. Connect the additional microphone pod to the conference link cable.



You can connect up to three microphone pods to the VSX 7000 set-top, or up to two microphone pods and a Visual Concert VSX data collaboration unit.

The cable from the system to the first microphone pod may be up to 50 ft. (15 m); cables farther from the system must be no more than 30 ft (9 m).

Visual Concert™ VSX™

You may connect a Visual Concert VSX unit to the VSX 7000 set-top if no more than two microphone pods are connected.

1. Connect a conference link cable to the available connector on the microphone pod and to one of the conference link connectors on the Visual Concert VSX unit.



The Visual Concert VSX and microphone pod(s) may be placed in any order.

2. Connect the LAN uplink connector on the Visual Concert VSX to the LAN. This connector is on the side farthest from the buttons.

This allows the Visual Concert VSX to provide LAN connections for up to three computers.

The Visual Concert VSX provides VGA output at a screen resolution of 1024 x 768 pixels, with a refresh rate of 60 Hz.

Refer to the *Visual Concert VSX QuickStart* for additional information.

Additional monitor or projector

1. Connect the dual display adapter cable option to the VGA output on the rear panel of the VSX 7000. The adapter allows you to connect a VGA, S-Video, or composite video cable.
2. Connect the monitor or projector to the dual display adapter cable using the appropriate cable.

You may connect a VGA monitor or projector directly to the Visual Concert VSX unit's VGA output, instead of using the VSX 7000 set-top's dual display adapter.



For high-resolution presentations using a Visual Concert VSX data collaboration unit, a VGA (computer) monitor is recommended as the second monitor.



You cannot connect a projector directly to the VSX 7000 if you have already installed a second monitor. Only one connector on the dual display adapter can be active at any given time. If a second monitor is connected, you may connect the projector through a Visual Concert VSX data collaboration unit.

Document camera or other additional camera

In addition to the Polycom PowerCam, the VSX system is also compatible with:

- Sony EVI-D30 (NTSC),
- Sony EVI-D31 (PAL),
- Sony EVI-D100 (NTSC), and
- Sony EVI-D100P (PAL).



The additional camera is stationary.

1. Connect the camera's S-Video output to the Camera 2 input.
2. Connect the camera's power pack or cord to a power outlet.



If you connect cameras or other devices to both the Camera 2 S-Video connector and the Camera 2 composite connector, the system only accepts the signal from the S-Video connector.

VCR or DVD — To Play



If you have connected a second camera to the camera 2 S-Video input, you cannot connect a VCR. The VCR inputs are not active when the S-Video connector is in use.

1. Connect the VCR or DVD's audio and video line out to the VCR inputs to the left of the camera 2 input.
2. Refer to the manufacturer's instructions for configuring the VCR or DVD.

The VCR inputs are active when you select camera 3.

VCR or DVD — To Record

1. Connect monitor 1 using the monitor 1 S-Video connector, and connect the VCR's audio and video line in to the monitor 1 RCA outputs. The VCR will record the same video and audio that monitor 1 receives.
2. Refer to the manufacturer's instructions for configuring the VCR.

3

Configuring Network Use

This chapter describes how to configure the system's network options.

When you power on your system for the first time, the setup wizard detects the system's IP and ISDN connections and leads you through the minimum configuration steps required to place a call.

If you need to change any of the initial settings, you can manually adjust them to accommodate your organization's environment by configuring the screens covered in this chapter.

Note that if you establish an administrator's password during the setup wizard, you will need to enter it each time you wish to change advanced settings.



To make sure you have all the information you'll need to configure network options, see *Preparing Your Network for Collaboration*, available at www.polycom.com/vidoeodocumentation.

What's in this Chapter?	Page
Accessing the System Screens	30
Configuring with the Setup Wizard	30
Configuring LAN Properties	31
Configuring IP Network Support	33
Configuring ISDN Support	39
Configuring Global Services	41
Placing a Test Call	48
Checking System Status	49
Keeping your Software Current	49

Accessing the System Screens

You can access the system to run the setup wizard or view the configuration screens in two ways.

- In the room with the system** — Use the remote control to navigate the screens and enter information. You can use the number pad on the remote control to enter text just like you can with a cell phone.
- From a remote location** — Use a web browser to access the VSX web interface. You need to know the IP address of the system. We recommend using Microsoft® Internet Explorer 6.0 or later.

To access the system via the VSX web interface:

1. Open a web browser on your computer.
2. In the browser address line, enter the system's IP address, for example, `http://255.255.255.255`.
3. Enter the user name and administrator's password, if a password has been established.

Configuring with the Setup Wizard

When you power on your system for the first time, the setup wizard detects the system's IP and ISDN connections and leads you through the minimum configuration steps required to place a call.

If you need more information about these steps, refer to the corresponding sections in this chapter.

Configuring LAN Properties

1. Go to **System > Admin Settings > LAN Properties**.
2. Configure these settings:

Setting	Description
Connect to my LAN	Specifies whether the system is part of the LAN.
Allow IP Calls	Enables the system to make and receive IP calls.
Host Name	Indicates the system's DNS name. If you change the Host Name, the system restarts.
IP Address	Specifies how the system obtains an IP address. Choose Obtain IP Address Automatically if the system gets an IP address from the DHCP server on the LAN. Choose Enter IP Address Manually if the IP address will not be assigned automatically.
Your IP Address is or Use the Following IP Address	If the system obtains its IP address automatically, this area displays the IP address currently assigned to the system. If you selected Enter IP Address Manually, enter the IP address here.
DNS Servers	Displays the DNS servers currently assigned to the system. If the system does not automatically obtain a DNS server address, enter up to four DNS servers here.
Default Gateway	Displays the gateway currently assigned to the system. If the system does not automatically obtain a gateway IP address, enter one here.
Subnet Mask	Displays the subnet mask currently assigned to the system. If the system does not automatically obtain a subnet mask, enter one here.
WINS Server	Displays the WINS server currently assigned to the system. If the system does not automatically obtain a WINS server IP address, enter one here.
WINS Resolution	Sends a request to the WINS server for WINS name resolution.

Setting	Description
LAN Speed	<p>Specify the LAN speed to use. Note that the speed you choose must be supported by the switch.</p> <p>Choose Auto to have the network switch negotiate the speed automatically. If you choose 10 Mbps or 100 Mbps, you must also select a duplex mode.</p>
Duplex Mode	<p>Specify the Duplex mode to use. Note that the Duplex mode you choose must be supported by the switch.</p> <p>Choose Auto to have the network switch negotiate the Duplex mode automatically.</p>

Configuring IP Network Support

Use the following sections to configure the system so that users can place and receive video calls using IP on your LAN or WAN:

- H.323 Settings
- Gatekeeper
- Gateway
- Quality of Service
- Firewall

Specifying H.323 Settings

If your network uses a Gatekeeper, the system can automatically register its H.323 name and extension. This allows others to call the system by entering the H.323 name or extension instead of the IP address.

1. Go to **System > Admin Settings > Video Network > IP Network > H.323 Settings**.
2. Configure these settings:

Setting	Description
Enable IP H.323	Specifies whether to allow IP dialing.
Display H.323 Extension	Lets users placing a gateway call enter the H.323 extension separately from the gateway ID. If you do not check this box, users make gateway calls by entering the call information in this format: gateway ID + ## + extension
H.323 Name	Specifies the name that gatekeepers and gateways use to identify this system. You can make point-to-point calls using H.323 names if both systems are registered to a gatekeeper. The H.323 Name is the same as the System Name, unless you change it. Your organization's dial plan may define the names you can use.
H.323 Extension (E.164)	Specifies the extension that gatekeepers and gateways use to identify this system. The default H.323 Extension is based on the system serial number, but it can be changed. Your organization's dial plan may define the extensions you can use.

Configuring the System to Use a Gatekeeper

A gatekeeper is a “network administrator” that supervises network traffic and manages functions such as bandwidth control and admission control. The gatekeeper also handles address translation, which allows users to make calls using static aliases instead of IP addresses that may change each day.

1. Go to **System > Admin Settings > Video Network > IP Network > Gatekeeper**.
2. Configure these settings:

Setting	Description
Use Gatekeeper	<p>Specifies whether to use a gatekeeper. Gateways and gatekeepers are required for calls between IP and ISDN networks.</p> <ul style="list-style-type: none"> • Off— Calls do not use a Gatekeeper. • Auto—System automatically finds an available gatekeeper. • Specify—Calls use the specified gatekeeper. Enter the gatekeeper's IP address or name (for example: gatekeeper.companyname.usa.com, or 255.255.255.255).
H.323 Name	<p>Specifies the name that gatekeepers and gateways use to identify this system. You can make point-to-point calls using H.323 names if both systems are registered to a gatekeeper.</p> <p>The H.323 Name is the same as the System Name, unless you change it. Your organization's dial plan may define the names you can use.</p>
H.323 Extension (E.164)	<p>Specifies the extension that gatekeepers and gateways use to identify this system.</p> <p>The default H.323 Extension is based on the system serial number, but it can be changed. Your organization's dial plan may define the extensions you can use.</p>
Outbound Call Route	<p>If you chose to use a gatekeeper, this specifies whether calls initiated by this system should be handled as IP calls sent through a gateway or as ISDN.</p>
Gatekeeper IP Address	<p>If you chose to use an automatically selected gatekeeper, this area displays the gatekeeper's IP address.</p> <p>If you chose to specify a gatekeeper, enter the IP address here.</p>

Configuring the System to Use a Gateway

A gateway connects two otherwise incompatible networks, performing code and protocol conversion between IP and ISDN protocols. If the system is configured to use a gateway, you must also configure it to use a gatekeeper.

1. Go to **System > Admin Settings > Video Network > IP Network > Gateway**.
2. Configure these settings:

Setting	Description
Country Code	Specifies the country code for the system's location.
Area Code	Specifies the area or city code for the system's location.
Number	Specifies the gateway's number.
H.323 Extension (E.164)	Specifies the extension that identifies this system for incoming gateway calls. The default H.323 Extension is based on the system serial number, but it can be changed.
Gateway Number Type	Specifies the type of number users enter to call this system: <ul style="list-style-type: none"> • Direct Inward Dial (DID)—Users enter an internal extension to call this system directly. Note: If you choose this option, you must also register the number with the gatekeeper as an E.164 alias. • Number + Extension—Users enter the gateway number + ## + Extension to call this system.
Number of Digits in DID Number	Specifies the number of digits in the DID number. The national or regional dialing plan for your location determines the standard number of digits. For instance, the US standard is 7 digits.
Number of Digits in Extension	Specifies the number of digits in the extension used for the DID number. Your organization's dial plan determines this number.

3. Select  and enter the required prefixes and suffixes for each call speed.



Associating prefixes and suffixes with particular bandwidths on your gateway can optimize the use of bandwidth by your organization. The gateway must also be configured to use the prefixes and suffixes you define.

Specifying Quality of Service

Set the Quality of Service options for the way your network handles IP packets during video calls.

1. Go to **System > Admin Settings > Video Network > IP Network > Quality of Service**.
2. Configure these settings:

Setting	Description
Type of Service	<p>Specifies your service type and lets you choose how to set the priority of IP packets sent to the system for video, audio, and far-end camera control:</p> <ul style="list-style-type: none"> • IP Precedence — Represents the priority of IP packets sent to the system. The value can be between 0 and 5. If this option is selected, enter the value in the Type of Service Value field. • DiffServ — Represents a priority level between 0 and 63. If this option is selected, enter the value in the Type of Service Value field.
Type of Service Value	Specifies the IP Precedence or Diffserv value for Video, Audio, and Far-End Camera Control.
Dynamic Bandwidth	Specifies whether to let the system automatically find the optimum line speed for a call.

Configuring the System for Use with a Firewall or NAT

A firewall protects an organization's network by controlling data traffic from outside the network. Unless the firewall is designed to work with H.323 videoconferencing equipment, it will prevent successful videoconferencing because it prevents unsolicited data from entering the network.

Network Address Translation (NAT) network environments use private internal IP addresses for devices within the network, while using one external IP address to allow devices on the LAN to communicate with other devices outside the LAN. If your system uses a NAT, it must be assigned a public IP address to communicate outside the LAN.

To set up the system to work with a firewall or NAT:

1. Go to **System > Admin Settings > Video Network > IP Network > Firewall**.
2. Configure these settings:

If your system is:	Configure the system this way:
Behind a firewall that is H.323 compatible	Do not select Fixed Ports .
Behind a firewall that is not H.323 compatible	<ol style="list-style-type: none"> 1. Select Fixed Ports. 2. Specify the TCP and UDP ports to use. The VSX system assigns a range of ports starting with the TCP and UDP ports you specify. In most cases, the range begins with port 3230 for both TCP and UDP^a
Connected to the IP network through a Virtual Private Network (VPN)	In the NAT Configuration , select Off .
Behind a NAT that is H.323 compatible	<ol style="list-style-type: none"> 1. In the NAT Configuration, select Auto to allow the system to determine the NAT Outside (WAN) Address automatically. 2. Select NAT is H.323 Compatible. 3. To display the system's NAT Outside (WAN) Address, go to Address Displayed in Global Directory and select Public. <p>If the NAT is H.323 compatible, you do not need to use fixed ports, and you do not need to specify the system's outside IP address.</p>
Behind a NAT that cannot automatically determine the system's outside IP address	<ol style="list-style-type: none"> 1. In the NAT Configuration, select Manual. 2. Enter the appropriate NAT Public (WAN) Address that callers from outside the LAN will use to call your system.

- a. You will also need to open the firewall's port 1720 to allow H.323 traffic.

Configure the VSX system for specific products as follows:

If you use this type of NAT or firewall:	Configure your VSX system this way:		
	Use Fixed Ports	System Is Behind a NAT	NAT is H.323 Compatible
Cisco® PIX® ^a	Yes	Yes	No
Cisco® Router NAT	No	No	No
Linksys®	Yes	Does not matter	No
Netgear®	No	No	Yes
SMC® Barricade™	Yes	Yes	No

- a. The Fix Up H.323 feature should not be selected.

Deployment outside a Firewall

Systems deployed outside a firewall are potentially vulnerable to unauthorized access. Visit the Polycom Security Center at www.polycom.com for timely security information. You can also register to receive periodic email updates and advisories.

Configuring ISDN Support

The VSX system supports the Quad BRI network interface for ISDN calling.

You can set up the ISDN Network option only if the system has an ISDN network interface module installed. The system detects the ISDN interface and displays only the required configuration options.

Configuring the Quad BRI network interface

1. Go to **System > Admin Settings > Video Network > ISDN Network**.
2. Configure these ISDN BRI Protocol settings:

Setting	Description
Enable ISDN H.320	Allows this system to make H.320 (ISDN) calls.
Number of ISDN Channels to Dial in Parallel	Specifies how many channels to dial at one time. You can specify up to 8 channels. If you experience network problems, decrease the number.
ISDN Switch Protocols	Specifies the protocol used by your network's switch.
Outside Line Dialing Prefix	Specifies the ISDN dialing prefix used to call outside the network.

3. Select  and enter the ISDN BRI numbers:

Setting	Description
Area Code	Specifies the area code for this system's location.
Directory Numbers	Specifies the numbers assigned to the B1 and B2 channels for each BRI line. The two numbers for a line may be the same or different, depending on the switch protocol in use.
Enable	Specifies whether to enable the associated ISDN line. If you selected Standard ETSI Euro ISDN protocol, you must enable all BRI lines that you expect to be active, and you must not enable lines that will not be connected. You may want to disable a particular line if there are problems with the line that generate continuing error messages.

The ISDN BRI Numbers screen also displays information for Country and Country Code. To specify the system's location, go to **System > Admin Settings > General Settings > Location**. The system automatically supplies the country code when you specify the country.

4. If you selected ISDN switch protocol is AT&T 5ESS Multipoint, NI-1, or Nortel DMS-100, select  and enter the ISDN BRI SPIDs provided by your service provider.

After you enter the SPIDs, the system verifies them. If the system is unable to verify the SPIDs, make sure the system is connected and that the ISDN numbers you entered are correct.

If you do not have the SPIDs from your service provider, you can click **Start** to Auto-Detect SPIDs.

Choosing Call Quality Options

The Call Quality options help you manage the network bandwidth used for calls placed from the Directory. You can specify the default and optional call settings for outgoing calls. You can also limit the call speeds of incoming calls.

1. Go to **System > Admin Settings > Video Network > Call Quality**.
2. If the system is configured for both IP and ISDN calls, specify the preferred call type for calls from this system.
Specify **Manual** to allow users to choose the call type.
3. Select  to go to **Preferred Speeds** and configure these settings:

Setting	Description
Preferred speed for placing calls	Specifies the default call quality to use for calls initiated from this system. If the far-end system does not support this quality, the system automatically negotiates a lower quality. Depending on the system configuration, users can change the call quality when they make a call.
Maximum speed for receiving calls	Specifies the maximum quality for calls to this system. Incoming calls above this quality are accepted at a lower speed.

4. Select  and choose the **Call Speeds** to allow on this system.

Configuring Global Services

If your organization uses the Polycom Global Management System™, you can configure the VSX system to be monitored by the Global Management System (GMS) server. GMS is a web-based client/server software tool that allows administrators to manage a network of videoconferencing systems.

Use the following sections to configure global services for the system:

- Directory Servers
- Private Network
- Dialing Rules
- Management Servers
- Account Numbers and Validation
- My Information

Configuring the Directory Server Settings

The Global Directory provides a list of other systems that are registered with the Global Directory Server. The other systems appear in the Directory, allowing users to place calls to other users by selecting their names from the global directory list.

1. Go to **System > Admin Settings > Global Services > Directory Servers**.
2. Configure these settings:

Setting	Description
Global Directory (GDS)	Specifies the IP address or DNS address of the Global Directory Server.
Register	Registers this system with the Global Directory Server.
Password	Lets you enter the Global Directory password, if there is one.
Display Global Addresses	Displays other registered systems in the Global Directory.
Display Name in Global Directory	Specifies whether to display the system's name in the global directories of other registered systems.
Save Global Directory to System	Copies the Global Directory to this local system.

Configuring the System for a Private Network

The Private Network ISDN Number provides a second number that can be used to call the system. If an organization's PBX has two different lines coming from different network providers, the Private Network Number identifies the additional lines needed after the first line connects.

The Private Network Number can also signal the PBX to route additional calls through the PBX instead of going outside the PBX through the trunk line.



Some PBX systems signal the same called number regardless of the number used to call an endpoint. In this situation, the private number method may not work.

1. Go to **System > Admin Settings > Global Services > Private Network**.
2. Enter the Private Network Numbers for each line.

Setting the Dialing Rules

If your system is connected to your organization's private network and also to a public network, you may need to specify the codes and prefixes necessary for dialing other systems. If your system is connected only to a public network, you do not need to enter any dialing rules.

When you define dialing rules, your system's Directory can display dialing information about other videoconferencing systems correctly, including all of the numbers, area codes, country codes, and international dialing access codes necessary for making calls from this system. For example, if your system is in Melbourne, the Directory displays the correct numbers and codes for dialing systems in Paris, New York, and Cape Town, just as they should be dialed from Melbourne.

1. Go to **System > Admin Settings > Global Services > Dialing Rules**.
2. Configure these Dialing Rules:

Setting	Description
Number of Digits in Extension	Specifies the number of digits in the extension used to call other systems with the same area code (or city code) and prefix. For example, if your system's number is 1-512-555-1212 and you can call a system at 1-512-555-1214 by entering 51214, your extension has 5 digits. Leave this field blank if the system is not connected to a PBX.
International Dialing Prefix	Specifies the prefix to use for placing international calls. This prefix is automatically added to international calls made from the Global Directory. Note that this overrides the international dialing prefix for the country specified in System > Admin Settings > General Settings > Location .
Public Network Access	Allows your system to use a public network for making calls.
Public Network Dialing Prefix	Specifies the prefix required by your PBX for calls that use the public network. This prefix is automatically inserted before dialing public network numbers from the Global Directory.
Public Network (same area code) Prefix	Specifies the prefix to use for Public Network calls between systems in the same area code.
Private Network Dialing Prefix	Specifies the prefix to use to call another system on the same private network.
Private Network Access	Allows your system to use a private network for making calls.

3. Select  to go to the next screen and configure these Dialing Rules:

Setting	Description
If Area Code = Dial Prefix	Lists the prefix to use for calls to specific area codes. For example, you may need to dial 9 before numbers with the 800 area code.
Always Dial Area Code	Specifies that calls to sites in the same area code must include the area code.
Dial 1+ for all USA calls	Specifies that calls to systems in the United States must include a "1" before the area code.

The following rules are used by your Global Directory server to provide your Directory with the correct numbers to dial any site that is registered with your Global Directory:

Call From:	Call To:	Type of Call Placed:
Public Network	Public Network	Public Network
Public Network	Private Network	Public Network
Private Network	Public Network	Public Network
Private Network	Private Network	Private Network

Viewing the Management Servers List

On networks managed by the Global Management System, several Global Servers may be configured to manage this system remotely. The system also has a primary Global Management System server that performs account validation. You can view information about these servers, but this information can only be changed by the GMS Administrator.

>> Go to **System > Admin Settings > Global Services > Management Servers**.

Requiring an Account Number for Calls

If your system is set up for use with the Global Management System, the system can prompt the user to enter an account number before placing a call. The account number is added to the Global Management System's Call Detail Record (CDR), and this information can be used for call tracking and billing purposes.

If you configure the system to validate the account number, calls placed without a valid account number are not completed. If you do not configure the system to validate account numbers, calls are completed regardless of whether the account number is valid. Account numbers are set up in GMS by the GMS administrator.

For more information about account validation, please contact your GMS administrator.

1. Go to **System > Admin Settings > Global Services > Account Validation**.
2. Specify whether to require an account number for placing calls and whether that number should be validated by the GMS server.

Adding My Information

If your system is managed by GMS, you can configure the VSX system so that users can request help from the GMS administrator.

1. Go to **System > Admin Settings > Global Services > My Information**.
2. Enter the contact information for the GMS administrator for technical support.

The following section illustrates the interaction between GMS and the system you are configuring.

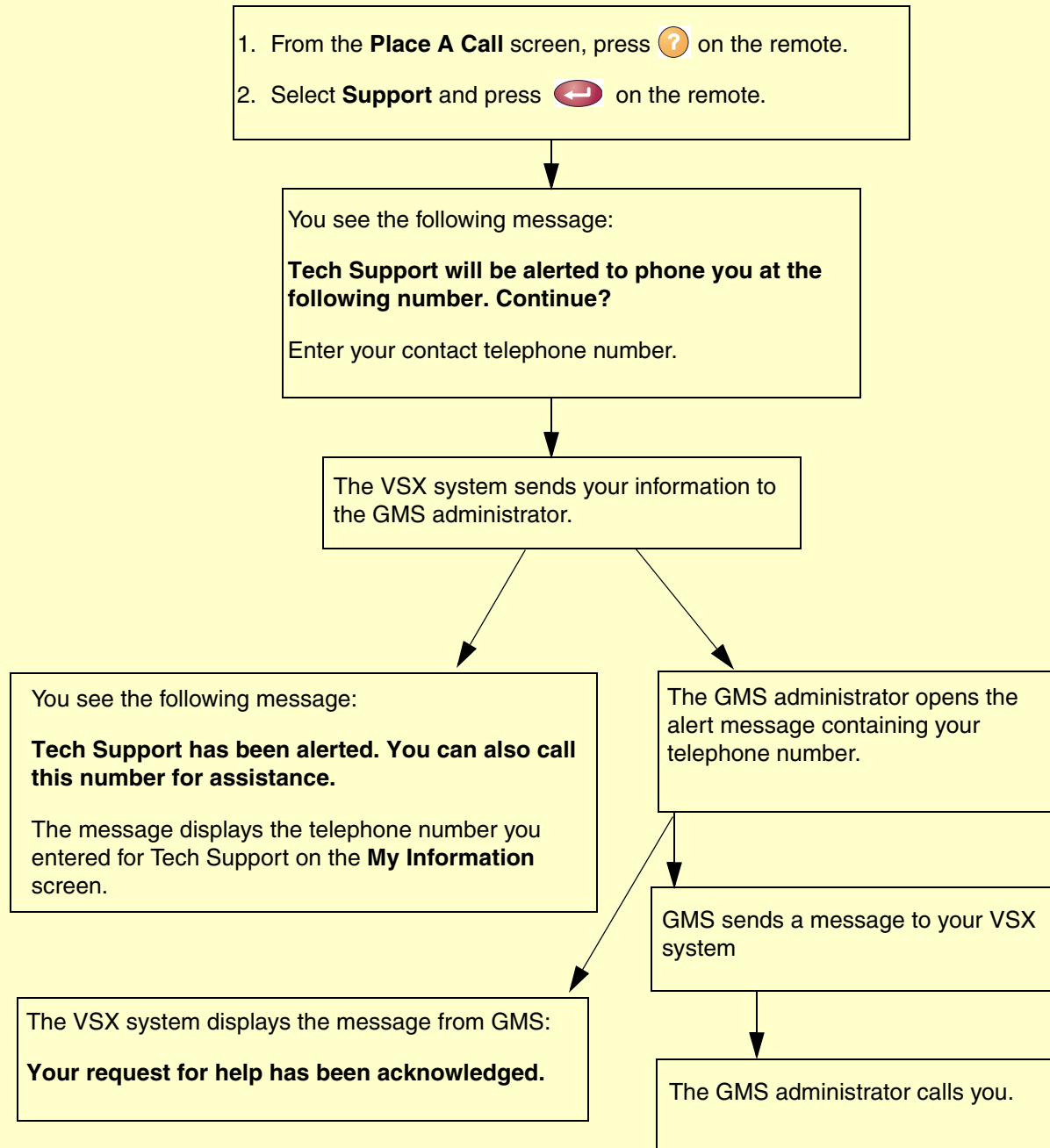

Requesting Technical Support from the GMS Administrator



Placing a Test Call

When you finish configuring the system, you can use one of the sample numbers in the Directory to test your setup.

To place a test call:

1. On the **Place a Call** screen, select .
2. Select **Category**.
3. Select **Sample Sites** and highlight a location.
4. Press  on the remote control.



You can also find a list of worldwide numbers that you can use to test your VSX system at www.polycom.com/videotest.

If you have trouble making video calls:

- Make sure the number you dialed is correct, then try the call again. For example, you may need to dial 9 for an outside line or include a long distance access code or country code.
- To find out if the problem exists in your system, ask the person you were trying to reach to call you instead.
- Find out if the system you are calling has its power turned on and is functioning properly.
- If you can make calls but not receive them, make sure that your system is configured with the correct number.

Checking System Status



The System Status screen provides detailed information about system settings, IP and ISDN connections, time server connections, and other information that is important to the functioning of the system. For an explanation of any of the status items, select the item and press  on the remote.

When there is a change in system status or a potential problem, you see an alert at the bottom of the Place a Call screen.

To view System Status information:

>> Go to **System > Diagnostics > System Status**.

To get information about a status message:

>> Select the status message with the remote control and press  or  on the remote.

Keeping your Software Current

If you have Internet access, you can use the web-based Softupdate application to upgrade the system software. If you do not have Internet access, your reseller can supply you with the updated software on CD-ROM.

Before you begin

Read the *Release Notes*, available at www.polycom.com/videosoftware, for the latest information about this software version.

To upgrade your software via the Internet:

1. From your PC, go to www.polycom.com/videosoftware, and download the software update file in .zip format.
2. Double-click the software .zip file to extract the file.
3. Double-click **Softupdate.exe**.
4. Click **Softupdate**, then enter the IP address of the system you want to update. Enter the administrator password, if required, and click **OK** to begin the upgrade.

5. On the **System Info** screen, select the other actions you want to occur during the update:
 - **Remove Address Book**—Check this option to delete your existing directory before the update.
 - **Remove System Files**—Check this option to delete your existing system files before installing new system files.
 - **Allow System to be a DHCP Server**—Check this option to allow this system to act as a DHCP server. If the system is on a LAN with other computers, the system will provide IP addresses to the other computers. In order to use this feature after the upgrade, you must enable it at **System > Admin Settings > LAN Properties**. If you do not check this option during the software update, the **Server** option will not be available on the **LAN Properties** screen.

Caution

Do not select **Allow System to be a DHCP Server** if your VSX system is on a LAN. If you do, the VSX system will provide IP addresses to the other computers on the LAN even though the LAN already has a DHCP server. Your IT personnel and system administrators will have to repair any network problems this causes.

6. Click **Continue** to upgrade the software.

Caution

Do not power off the system during the software upgrade process. If the upgrade is interrupted, the system reverts to its original software version.

4

Designing the User Experience

This chapter describes how to design the videoconferencing experience for the needs of your users. You can customize the behavior and system appearance to accommodate a range of videoconferencing applications. This chapter also covers how to build in different access levels for users, depending on how much or little you want users to change the system behaviors you establish.

When you set up the system for the first time, the system is configured with the most commonly-used behaviors by default. If you need to change any of the initial settings, you can manually adjust them to accommodate your organization's environment by configuring the screens described in this chapter.

If you established an administrator's password during the initial configuration, you must enter it each time you change advanced settings.

What's in this Chapter?	Page
Managing User Access to Settings and Features	52
Designing Video and Audio Behaviors	56
Customizing the Workspace Appearance	63
Designing General System Behaviors	70
Helping Users Get Started	75

Managing User Access to Settings and Features

You can manage user access to settings and features by using passwords and by explicitly configuring the system to show only those options you want your users to see.

To maintain this security level...	You can allow users to:
High (Kiosk mode)	Call only the numbers you specify on the Home screen. See Using the System for Specialized Applications on page 55 and on page 64 .
Medium	Place calls using the restrictions you specify for length of call, type of call, and use of the Directory. See Limiting What Users Can Do With the System on page 55 .
Low	Configure user settings. See Letting Users Customize the Workspace on page 54 .
Very low	Configure all system settings.

Setting the Admin Password

Set an administrator's password to restrict who can:

- Make changes other than those in the User Settings screen
- Update the software
- Perform remote management using the VSX web interface

To set or change the Admin Password:

1. Go to **System > Admin Settings > General Settings > Security**.
2. Enter or change the password.

The following diagram shows top-level system screens. All screens within Admin Settings require the administrator's password.

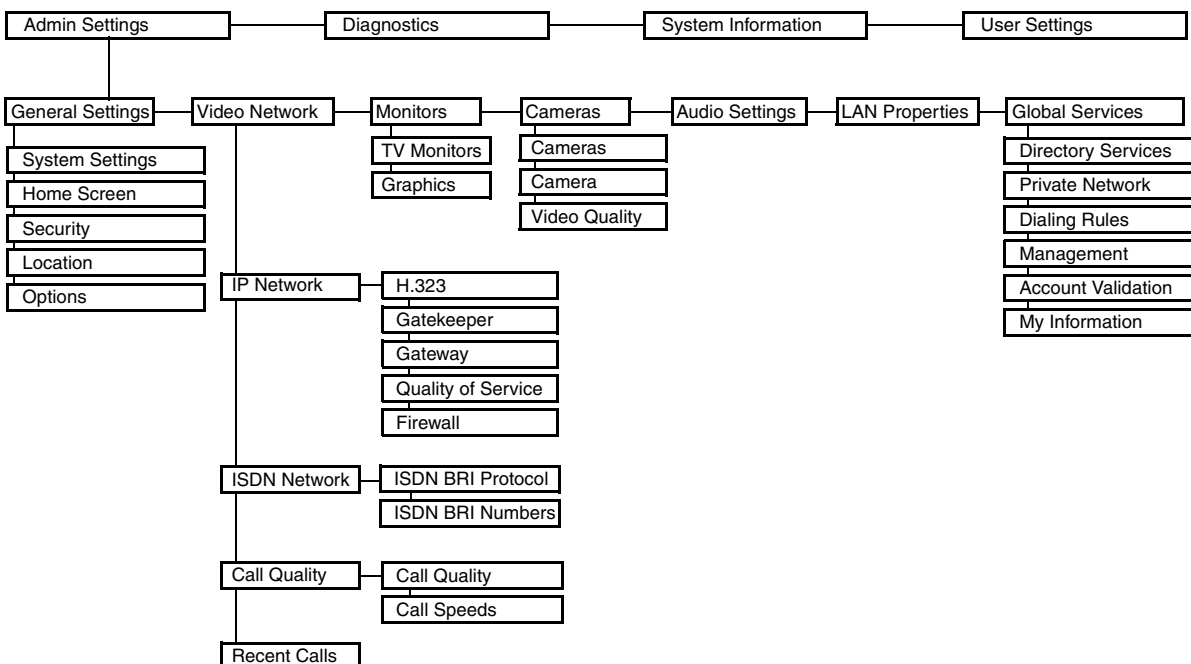

Letting Users Customize the Workspace

You can allow users to change common user preferences by providing access to the User Settings screen.

1. Go to **System > Admin Settings > General Settings > System Settings**, then select .
2. Check the **Allow User Settings** option.
The **User Settings** button appears on the **System** screen.

User Settings contains the following options:

- Backlight Compensation
- Far Control of Near Camera
- Meeting Password
- Auto-Answer Point to Point
- Auto-Answer Multipoint
- Mute Auto-Answer Calls
- PIP adjustment
- Keypad Audio Confirmation
- Color Schemes
- Far Site Name Display Time



These options are also available to administrators on the Admin Settings screens.

Limiting What Users Can Do With the System

You can limit what you allow users to do with the system by configuring the following:

- Maximum time in call** — Go to **System > Admin Settings > General Settings > System Settings** and specify the maximum call length allowed.
- Allow mixed IP and ISDN calls** — If you do not want to allow mixed calls on your system, clear this selection.
- Allow Directory changes** — If you do not want users to save changes to the local directory of the system, clear this selection.

Using the System for Specialized Applications

You can customize the system to show only a specific set of numbers to call. This mode, also known as “kiosk mode,” can be used for specialized applications, such as customer query stations or systems used for calling the same numbers on a regular basis. Kiosk mode requires little or no training and instructions can be incorporated into the screen design.

See [Designing the Home screen on page 64](#) for more details about the kiosk mode and its applications.

Designing Video and Audio Behaviors

Use the following sections to configure the video and audio behaviors to accommodate your environment:



- Camera Settings and Video Quality
- TV Monitors
- Dual-Monitor Emulation
- High-Resolution Displays
- Audio Quality

Configuring Camera Settings and Video Quality Options

The Video Quality screen lets you set the video inputs for either motion or sharpness, as appropriate for the equipment you are using:

1. Go to **System > Admin Settings > Cameras**.
2. Configure these settings:

Setting	Description
Far Control of Near Camera	Specifies whether the far site can control the position of the near site camera. When this option is selected, a user at the far site can control the framing and angle of the camera for the best view of the near site.
Backlight Compensation	Specifies whether to have the camera automatically adjust for a light background. Backlight compensation is best used in situations where the subject appears darker than the background.
Primary Camera	Specifies which camera is the main camera.
Camera Direction	Specifies the direction the camera moves when using the arrow buttons on the remote control.

3. Select  and add names and specify icons for each video source.
4. Select  to go to **Video Quality**.
5. Select **Motion** or **Sharpness** for the video inputs:
 - If you select **Motion**, moving people or objects move smoothly, but the picture may lose some detail. This setting is best for an auxiliary camera or a VCR.
 - If you choose **Sharpness**, the picture will be sharp and clear, though motion may not be smooth. Choose this setting for document cameras.



Sharpness is available in point-to-point calls only.

6. Specify when to use **Pro-Motion** for video inputs set for motion.



Pro-Motion™ provides 50/60 fields per second interlaced video for TV-like quality at higher bandwidths.

Configuring TV Monitors

The VSX system allows you to customize displays to suit your room and equipment configuration, including choosing the monitor for presenting content.

1. Go to **System > Admin Settings > Monitors > TV Monitors**.
2. Configure these settings:

Setting	Description
Monitor 1	Specify whether you are using a regular monitor or a wide screen monitor.
Monitor 2	Specify the second monitor behavior: <ul style="list-style-type: none"> • Off — Select if you do not have a second monitor. • 4:3 — Select if you are using a TV monitor as the second monitor. • VGA — Select if you are using a VGA monitor as the second display device. <p>Note: If you are using a second monitor, you must use the dual display adapter option.</p>
PIP	Specify PIP (Picture-in-Picture) behavior: <ul style="list-style-type: none"> • Camera — The PIP window is displayed when the call is first connected and when a user moves the camera, uses presets, or switches to a different camera source. • On — The PIP window stays on for the duration of the call. • Off — The PIP window is not displayed during the call. • Auto — The PIP is displayed when a user picks up the remote. <p>Note: PIP settings are also available in the User Settings screen.</p> <p>Users can turn the PIP on or off and change its location on the screen using the PIP button on the remote.</p>
Graphics Content Display	Specifies the monitor for the display of graphics content, when you are using two monitors. <p>Note that if the far site does not have dual-stream capability, content will appear on Monitor 1 at all sites.</p>
Display Icons in a Call	Specifies whether to display all on-screen graphics, including icons and help text, during calls.
Snapshot Timeout	Specifies how long to display snapshot images received from the far site.
Dual Monitor Emulation	Specifies whether both sites are displayed in a split-screen mode when using one monitor.

Using Dual Monitor Emulation

Dual Monitor Emulation is designed for rooms or offices with one monitor only. Users see both near and far sites on one monitor in two different views. During presentations, users see content *and* the near and far sites.

Setting Up

On **TV Monitors** screen:

1. Set Monitor 1 to **4:3** or **16:9**.
2. Set Monitor 2 to **Off**.
3. Select **Dual Monitor Emulation**.

Using in a Call

Call Connects

Near and far site are the same size and appear side by side.

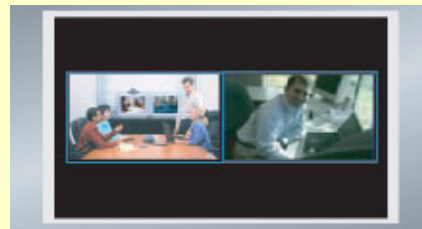

Far site

Near site

Near site presses PIP

To increase size of far site window.



Near site presents to far site

Content, near site, and far site are displayed in dual monitor emulation mode.



Using a High-Resolution Display to Show Content

With the Visual Concert VSX data collaboration unit, you can present content during calls on a high-resolution display.

1. Go to **System > Admin Settings > Monitors > Graphics VGA**.
2. Configure these settings:

Setting	Description
VGA Output with No Graphics	States that the screen appears Black when there is no content to display.
VGA Resolution	Specifies the VGA resolution for your monitor. Select the maximum VGA resolution that your monitor or projector can support. Consult the user manual provided with the VGA monitor or projector for performance.

3. Connect the Visual Concert VSX unit as described in [Connecting Additional Equipment on page 25](#).

Configuring Audio Settings

1. Go to **System > Admin Settings > Audio Settings**.
2. Customize these settings:

This setting:	Allows you to:
Sound Effects Volume	Set the volume level of the ring tone and user alert tones.
Incoming Video Call	Select the ring tone used for incoming calls.
User Alert Tones	Select the tone used for user alert tones.
Mute Auto-Answer Calls	Select whether to mute incoming calls. Incoming calls are muted by default until you press the mute button on the microphone pod or the remote control.

3. Select  and enter line input and output settings:

This setting:	Allows you to:
Line Input (Red) Line Input (White)	Specify the equipment you are connecting to the audio input connectors on the back of the unit – an audio mixer, or the audio connections for a VCR.
Line Outputs	Specify how the audio output behaves. The default selection, Monitor - Far Site Audio , supplies audio to the Monitor 1 audio outputs only when the system is receiving audio from the far site. If you have connected a VCR to record the conference, select VCR - Far and Near Audio to supply audio from both the far site and the system's microphone pods to the VCR.
Level	Set the volume level for the line with which it is associated.

4. Select  and enter speaker settings:

This setting	Allows you to:
Master Audio Volume	Set the volume level for audio from the far site.
Midrange Speaker	Use the system's built-in midrange speaker, or turn it off. You may prefer to turn off the midrange speaker if you connect the audio output to Monitor 1.
Subwoofer Speaker	Use the system's subwoofer, or turn it off. You may prefer to turn off the subwoofer speaker if you connect the audio output to Monitor 1. The system will not operate if you disconnect the subwoofer.
Subwoofer Offset	Adjust the volume level for the subwoofer without changing the master audio volume.
Bass	Adjust the volume level for the lower frequencies without changing the master audio volume.
Treble	Adjust the volume level for the higher frequencies without changing the master audio volume.

Customizing the Workspace Appearance

You can customize the VSX workspace appearance to suit the users' environment functionally and aesthetically.

For example, by customizing the Home screen into kiosk mode, users only have to select a site and press the  **Call-Hang Up** button on the remote control to place a call.

Use the following sections to configure the general appearance of the system:

- Designing the Home screen
- Adding Sites
- Adding Instructions to the Interface
- Specifying Camera Icons and Names
- Changing Color Schemes
- Setting Ring Tones

Designing the Home screen

Customize the system functionality according to your users' needs, skill levels, and environments.

Infrequent Users (Kiosk Mode)

- Provides a simple workspace so no training is needed.
- Lets users make calls to pre-defined numbers with one button click.
- Include instructions on screen.

User selects insurance type

Use marquee to add instructions

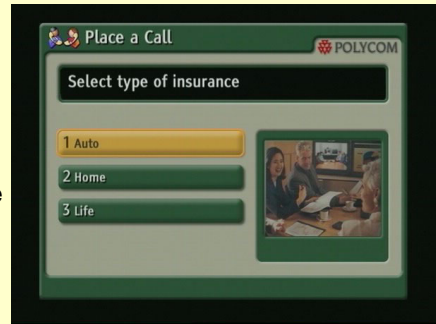

New Users

Provide more options but keep it simple:

- Dialing entry field
- Directory numbers
- Recent Calls

Add features for users as needed

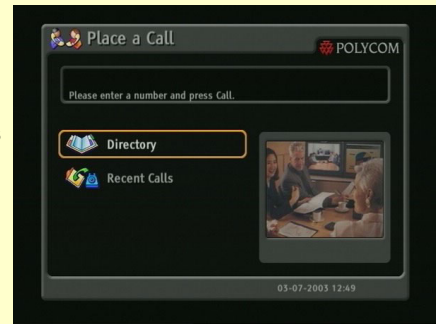

Advanced Users

Provide additional options for advanced videoconferencing users:

- Call Quality
- Multipoint dialing
- User Settings, Diagnostics, and System Information
- Speed Dial list of frequently-called sites

Add features as users gain experience

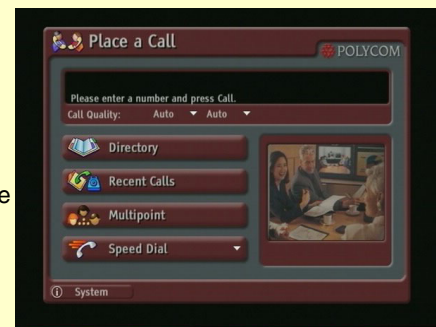

1. Go to **System > Admin Settings > General Settings > Home Screen Settings**.
2. Customize these options:

Setting	Description
Dialing Display	Specifies which dialing option to display: <ul style="list-style-type: none"> • Dialing entry field — Allows users to enter numbers manually. • Display marquee — Displays text in the dialing entry field. Can be used to display user instructions. Users cannot enter numbers manually when this option is selected. • None — Removes the dialing entry field from the screen.
Call Quality	Allows users to select the bandwidth for calls.
H.323 Extension (E.164)	Allows users to enter extensions on the Home screen.
Directory	Allows users to access the Directory.
System	Allows users to access the System screen, which includes User Settings, Diagnostics, and System Information.
Multipoint	Allows users to access the multipoint dialing screen via a Multipoint button on the Home screen.



If you remove the System button, you can still access the System screen by navigating to the Home screen, pressing  on the remote, and selecting **System**.

3. Select  and configure these settings:

Setting	Description
System Name	Specifies whether to display the name of the system on the Home Screen above the PIP window.
IP or ISDN Information	Specifies whether to display the system's IP address, ISDN number, or both on the Home screen.
Local Date and Time	Specifies whether to display the local time on the Home screen.
Do Not Disturb	Allows users to set the system to automatically accept or ignore incoming calls via the Do Not Disturb button on the Home screen.
Call Detail Report	Specifies whether to generate a report of all calls made with the system. When selected, details all calls can be viewed via the web interface and downloaded as a .csv file.
Recent Calls	Allows users to access a list of recent calls made with the system by displaying the Recent Calls button on the Home screen. Note that if Call Detail Report option is not selected, the Recent Calls option is not available.
Sites	Allows users to access any pre-defined sites from a My Contacts/Speed Dial list on the Home screen.

4. Select  and specify any Site names you wish to display on the Home screen.

Adding Sites

Creating Site buttons on the Home Screen makes it easy for users to place calls to sites that they call on a regular basis.

Sites can appear as individual buttons or as part of a list called **Speed Dial** or **My Contacts**.



You must enter the site information in the Directory before creating specific site buttons for the Home screen.

1. Go to **System > Admin Settings > General Settings > Home Screen Settings**.
2. Select  twice to access the **Sites** screen.
3. Select **Add** and choose the sites to add from the Directory.
4. Specify the name you want to appear on the Home screen button.

Adding On-screen Instructions

Using Marquee Text

By customizing the dialing entry field to display text, you can create context-specific instructions for your users. If the Home screen has site buttons, the marquee text can provide information that helps users choose which site to call.

1. Go to **System > Admin Settings > General Settings > Home Screen Settings**.
2. In **Dialing Display**, select **Display Marquee** and enter the text.



You can also add marquee text via the VSX web interface.

Using Screen Saver Text

You can customize the VSX system to display on-screen instructions when the system is in sleep mode, to assist users with next steps.

1. Open a web browser and enter the system IP address in the address line.
2. Enter the user name and administrator's password, if a password has been established.
3. Click **Utilities > Screen Saver** and enter:
 - **Logo screen text** — appears underneath the logo, prior to the system going into sleep mode.
 - **Sleep text** — appears as scrolling text when the system is in sleep mode.

Changing Color Schemes

Different user interface color schemes are available, allowing you to coordinate the system interface with the meeting room décor.

1. Go to **System > Admin Settings > General Settings > System Settings**, then select  twice.
2. Select a color scheme.

You can allow users to change color schemes by allowing user access to the User Settings screen.

Customizing Camera Names and Icons

Customizing the way cameras appear on screen helps users select the correct camera input during a call. You can enter camera names and assign icons. You can choose camera icons from categories including Corporate, Education, Justice, Manufacturing, and Medical.

Setting Up

1. Go to **System > Admin Settings > Cameras**, then select  to go to **Camera Settings**.
2. Enter camera names and select the appropriate icon for each video source.

Select icons that make sense in the users' environment or industry.

Using in a Call

With customized camera names and icons, users can select the correct camera source during a call, quickly and without rehearsal or experimentation.

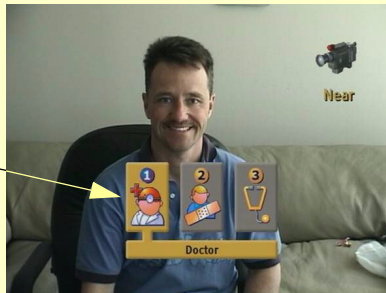

Setting Ring Tones and Alert Tones

1. Go to **System > Admin Settings > Audio Settings**.
2. Select a tone, as desired.

Designing General System Behaviors

Configure the general behavior of the system to accommodate your environment:

- System Settings
- Multipoint Calling
- Call Quality Preferences
- Call Answer Mode
- Passwords and Security Options
- Date, Time, and System Location

Configuring System Settings

The System Settings screen provides access to high-level options for the entire system. For convenience, some of the User Settings options are repeated.

1. Go to **System > Admin Settings > General Settings > System Settings**.
2. Configure these settings:

Option	Description
System Name	Enter or change the system name in this field. This name appears on the screen for the far site when you are making calls.
Maximum Time in Call	Enter the maximum number of minutes allowed for call length. When that time has expired, you see a message asking you if you want to hang up or stay in the call. If you do not answer within one minute, the call automatically disconnects.
Allow Mixed IP and ISDN calls	Specifies whether users can make multipoint calls that include both IP and ISDN sites. Unchecking this option provides extra security for systems requiring LAN connectivity while placing encrypted calls over ISDN lines. If you clear this selection, IP endpoints cannot join ISDN calls.
Auto-Answer Point to Point	Specifies whether to answer incoming point-to-point calls automatically.
Auto-Answer Multipoint	Specifies whether to accept incoming multipoint calls automatically.

3. Select  and configure these settings:

Option	Description
Allow Directory Changes	Specifies whether users can save changes they make to the Directory.
Confirm Directory Additions	Specifies whether users are prompted to confirm new Directory entries when saving.
Confirm Directory Deletions	Specifies whether users are prompted to confirm deletions of Directory entries.
Allow Access to User Settings	Specifies whether the User Settings screen is accessible to users via the System screen. Uncheck this option if you do not want users to change environmental settings.
Far Site Name Display Time	Specifies the time period the far site name appears on screen when calls first connect.
Display Time in Call	Specifies whether to display the elapsed time or the local time during a call. You can also choose not to display the time.

4. Select  and configure these settings:

Option	Description
Keypad Audio Confirmation	Specifies whether to play a voice confirmation of numbers selected with the remote control.
Call Detail Report	Specifies whether to generate a report of all calls made with the system. When selected, details for all calls can be viewed via the VSX web interface and downloaded as a .csv file.
Recent Calls	Specifies whether to display the Recent Calls button on the Home screen. The Recent Calls screen lists the site number or name, the date and time, and whether the call was incoming or outgoing. Note that if Call Detail Report option is not selected, the Recent Calls option is not available.
Color Scheme	Customizes the look of your system with different color schemes.
Screen Saver Wait Time	Specifies how long the system remains awake during periods of inactivity.

Configuring Multipoint Calling

Before placing multipoint calls, you must enter a multipoint software registration key.

1. Go to **System > Admin Settings > General Settings > Options**.
2. Enter the multipoint key provided.

For information about purchasing the multipoint call option, please contact your Polycom distributor.

Setting Call Quality Preferences

Use the Call Quality screens to customize bandwidth options for incoming and outgoing calls.

1. Go to **System > Admin Settings > Video Network > Call Quality**.
2. Select your primary and secondary call type choices for calls being placed from the local and global directories.

If the sites in your directory have both IP and ISDN numbers, these settings determine your network preferences for placing the call.

3. Select  to go to the **Preferred Speeds** screen and configure these settings:



Option	Description
Preferred Speeds for Placing Calls	Determines the speeds that will be used for calls when <ul style="list-style-type: none"> • Call Quality is set to Auto on the Home screen • Call Quality option is not available for users
Maximum Speeds for Receiving Calls	Allows you to restrict the bandwidth used when receiving calls. If the far site attempts to call the system at a higher speed than selected here, the call is re-negotiated at the speed specified in this field.

4. Select  to go to the **Call Speeds** screen and specify the call speeds to make available to users, if you are allowing them to choose speeds on a call-by-call basis.

Setting the Call Answering Mode

1. Go to **System > Admin Settings > General Settings > System Settings**.
2. Select **Auto-Answer Point to Point** to set the answer mode for calls with one site, or select **Auto-Answer Multipoint** to set the mode for calls with two or more other sites.
3. Choose from the following:
 - **Yes** – to answer calls automatically
 - **No** – to answer calls manually
 - **Do Not Disturb** – to refuse incoming calls automatically. The caller receives a message that the site is unavailable.

Setting Passwords and Security Options

1. Go to **System > Admin Settings > General Settings > Security**.
2. Configure these settings:

Setting	Description
Admin Password	<p>Enter or change the Admin Password.</p> <p>When the Admin Password is set, you must enter this password to</p> <ul style="list-style-type: none"> • make configuration changes not in the User Settings screen, • update the software, or • manage the system using the VSX web interface.
Meeting password	<p>Specifies the password users must supply to join multipoint calls on this system if the call uses the internal multipoint option, rather than an external MCU.</p> <p>This field can also be used to store a password required by another system that this system calls. If a password is stored in this field, you do not need to enter it at the time of the call; the VSX system supplies it to the system that requires it.</p>
Enable Remote Access	<p>Specifies whether to allow remote access to the system by</p> <ul style="list-style-type: none"> • FTP, • Telnet, or • VSX web interface.

Setting Date, Time, and Location

You can update the system with regional settings, including the location-specific language and calling parameters.

1. Go to **System > Admin Settings > General Settings > Location**.
2. Configure these settings:

Setting	Description
Country	Specifies the country where the system is located. Changing the country automatically adjusts the country code associated with your system number.
Language	Sets the language for the user interface.
Country Code	Specifies the country code for the system location.
Area code required	Specifies the area code for the system location.
ISDN International Access	Specifies the international code required for placing ISDN calls from the system location to another country.
Room Telephone Number	Enter the telephone number of the room where the system is located.

3. Select  and enter Date and Time information:

Setting	Description
Date and Time	Specifies your format preference for the date and time display and lets you enter your local date and time.
Daylight Savings Time	Specifies whether it is daylight savings time.
Time Difference from GMT	Specifies the time difference between GMT (Greenwich Mean Time) and your location.
Display Time in Call	Specifies the time display in a call: <ul style="list-style-type: none"> • Elapsed Time – Displays the amount of time in the call. • Local Time – Displays the local time on the screen during a call. • Off – Select this option if you do not want a time display.
Time Server	Specifies connection to a time server for automatic system time settings.

Helping Users Get Started

The system is installed and you've finished the network configuration and designed the look and behaviors. Now it's time for the users to start placing calls. You may want to spend some time helping your users become familiar with basic calling tasks.

The following resources are available for users:

- ❑ **VSX Series Getting Started Guide** — This guide is for all users, from beginners to the more experienced. It covers meeting basics, different ways to place calls, how to use the remote control, and how to deliver presentations. It is included on the VSX system documentation CD and is also available on the web. Print out copies to hand out in training classes, post it on your Intranet, or email it to everyone in your organization who meets via video.
- ❑ **Visual Concert VSX Quick Tips** — This two-page guide shows users how to present content with the Visual Concert VSX. It is included on the VSX system documentation CD and is also available on the web. Email it to your users so they can print a copy whenever they are presenting content with the Visual Concert VSX.
- ❑ **Screen Help** — The Place a Call and Directory screens have context-specific Help. Users can press  on the remote control to access help topics.
- ❑ www.polycom.com/videodocumentation — Refer to the video documentation page on the Polycom website for the latest documents supporting this product.

5

System Usage and Statistics

The VSX system provides various screens that allow you to review information about calls made by the system, and network usage and performance.

What's in this Chapter?	Page
Call Summary	78
Call Statistics	79
Call Status	80
Recent Calls	82
Call Detail Report	82

Call Summary

The Call Summary screen provides details about the calls placed by the system, including:

- Duration of the last call
- Total number of calls placed and received
- Number, percentage, and total time of IP calls
- Number, percentage, and total time of ISDN calls

To view Call Summary:

>> Go to **System > Diagnostics > Call Statistics**, then select  to view the **Call Summary** screen.



You can view Call Statistics and Call Summary during a call by pressing  on the remote.

Call Statistics

The two Call Statistics screens provide information about the call in progress, including:

This screen:	Displays this information:
Call Statistics (1)	<ul style="list-style-type: none"> • Call speed (transmit and receive) • Video protocol and annexes in use (transmit and receive) • Audio protocol in use (transmit and receive) • Number of packets lost and percentage packet loss (transmit and receive) • Far site details and call type
Call Statistics (2)	<ul style="list-style-type: none"> • Audio and video data rates specified (transmit and receive) • Video data rate and frame rate in use (transmit and receive) • Video packet loss and jitter • Audio packet loss and jitter • Far site details and call type

To view Call Statistics:

>> Go to **System > Diagnostics > Call Statistics**, then select  to view the **Call Statistics** screen.



You can view Call Statistics and Call Summary during a call by pressing  on the remote.

Call Status

The Call Status screen provides call connection details. The spheres provide details for each line, and when you place a call you'll see the status change as the call connects.

You can highlight the spheres on this screen to see details of the number dialed, the relevant status code, as well as details of any errors.

To view Call Status:

>> Go to **System > Diagnostics > Call Statistics**.



You can view **Call Status** during a call by pressing  on the remote.

Recent Calls

Recent Calls shows a list of up to 99 calls made by the system. It includes the following information:

- Site name or number
- Date
- Time
- Call In or Out

The Recent Calls list shows only calls that connect. If Do Not Disturb has been enabled, any incoming calls attempted by other sites will not be listed.



To view Recent Calls:

>> Go to **System > Admin Settings > Video Network > Recent Calls.**



The Home screen can be configured to include Recent Calls. For more information about including the Recent Calls list on the Home screen, see [Designing the Home screen on page 64](#).

You can see more detail about any call by selecting an entry and pressing  on the remote. Information includes the far site's number and the type, duration, and speed (bandwidth) of the call.

You can call any site on the Recent Calls list by highlighting the entry and pressing  or  on the remote to place the call.



If you need even more detail about calls, the Call Detail Report (CDR) can be downloaded from the VSX web interface.

Call Detail Report

The Call Detail Report (CDR) provides the VSX system's call history. You can view the CDR from the VSX web interface, and you can download the data in CSV format for sorting and formatting.



CSV stands for Comma Separated Value. CSV files can be imported into spreadsheet and database programs.

Every call that connects is added to the CDR, whether it is a call that you make or that you receive. If a call does not connect, the report shows the reason. In multipoint calls, each far site is shown as a separate call, but all have the same conference number.

The CDR does not include incoming calls that the VSX system does not answer, so if calls were missed while Do Not Disturb was enabled, details will not be included in the CDR.

To view and download the CDR via the web interface:

1. Open a web browser and enter the system IP address in the address line.
2. Enter the user name and administrator's password, if a password has been established.
3. Click **System Setup > Utilities > Call Detail Report** to view the details of the file.
4. Click **Download**, then in the **File Download** dialog click **Save** and specify a location on your computer to save the file.

Information in the CDR

The following table describes the data fields in the CDR.

Data	Description
Row ID	Each call is logged on the first available row. A call is a connection to a single site, so there may be more than one call in a conference.
Start Date	The call start date, in the format dd-mmm-yyyy.
Start Time	The call start time, in the 24-hour format hh:mm:ss.
End Date	The call end date.
End Time	The call end time.
Call Duration	The length of the call.
Account Number	If Require Account Number to Dial is enabled on the system, the value entered by the user is displayed in this field.
System Name	The far site's system name.
Call Field Number 1	The number dialed from the first call field, not necessarily the transport address. For incoming calls —The caller ID information from the first number received from a far site.
Call Field Number 2 (If applicable for call)	For outgoing calls—The number dialed from the second call field, not necessarily the transport address. For incoming calls—The caller ID information from the second number received from a far site.
Transport Type	The type of call — either H.320 (ISDN) or H.323 (IP).
Call Rate	The bandwidth negotiated with the far site.
System Manufacturer	The name of the system manufacturer, model, and software version, if they can be determined.
Call Direction	In—for calls received. Out—for calls placed from the system.
Conference ID	A number given to each conference. A conference can include more than one far site, so there may be more than one row with the same conference ID.
Call ID	Identifies individual calls within the same conference.
Total H.320 Channels Used	The total number of ISDN B channels used in the call. For example, a 384K call would use six B channels.
Endpoint Alias	The alias of the far site.
Endpoint Additional Alias	An additional alias of the far site.
Endpoint Type	Terminal, gateway, or MCU.
Endpoint Transport Address	The actual address of the far site (not necessarily the address dialed).
Audio Protocol (Tx)	The audio protocol transmitted to the far site, such as G.728 or Siren14.

Data	Description
Audio Protocol (Rx)	The audio protocol received from the far site, such as G.728 or G.722.
Video Protocol (Tx)	The video protocol transmitted to the far site, such as H.263 or H.264.
Video Protocol (Rx)	The video protocol received from the far site, such as H.261 or H.263.
Video Format (Tx)	The video format transmitted to the far site, such as CIF or SIF.
Video Format (Rx)	The video format received from the far site, such as CIF or SIF.
Reason for Disconnect	The description of the Q.850 (ISDN) cause code showing how the call ended.
Q.850 Cause Code	The Q.850 cause code showing how the call ended.
Total H.320 Errors	The number of errors during an H.320 call.
Percent of Packet Loss (Tx)	The percentage of packets transmitted that were lost in the previous 5 seconds during an H.323 call.
Percent of Packet Loss (Rx)	The percentage of packets from the far site that were lost in the previous 5 seconds during an H.323 call.
Total Packets Lost (Tx)	The total number of packets transmitted that were lost during an H.323 call.
Total Packets Lost (Rx)	The total number of packets from the far site that were lost during an H.323 call.
Average Latency (Tx)	The average latency of packets transmitted during the call, calculated from sample tests done once per minute.
Average Latency (Rx)	The average latency of packets received during the call, calculated from sample tests done once per minute.
Maximum Latency (Tx)	The maximum latency for packets transmitted during the call, calculated from sample tests done once per minute.
Maximum Latency (Rx)	The maximum latency for packets received during the call, calculated from sample tests done once per minute.
Average Jitter (Tx)	The average jitter of packets transmitted during the call, calculated from sample tests done once per minute.
Average Jitter (Rx)	The average jitter of packets received during the call, calculated from sample tests done once per minute.
Maximum Jitter (Tx)	The maximum jitter of packets transmitted during the call, calculated from sample tests done once per minute.
Maximum Jitter (Rx)	The maximum jitter of packets received during the call, calculated from sample tests done once per minute.

Call Detail Report (CDR) Archives

Calls are added to the CDR until the file size reaches 50 KB, which is equivalent to about 150 calls. The system then automatically archives the CDR and creates a new CDR file. If an archive is already present, the new archive overwrites it.

Each CDR starts with Row 1, but the conference numbers continue from the file most recently archived. Conference numbering restarts at 1 after the system assigns conference number 100,000.

To get an archived CDR:

1. From your computer, open an FTP client.
2. FTP into the VSX system.
3. Enter this FTP command:
`GET localcdr_archive.csv`
4. Close your FTP session.

6

Diagnostics and General Troubleshooting

This chapter covers the diagnostic screens of the VSX system. It is organized by category to help you troubleshoot any issue.

Diagnostic tools are available via the system itself and the system's web server. To connect to your system's web server and troubleshoot via the web, enter your system's IP address in a web browser and browse to the required diagnostic tool.

What's in this Chapter?	Page
Sending a Message	88
System Screens Quick Reference	88
Diagnostic Screens	89
General Troubleshooting	96
How to Contact Technical Support	105

Sending a Message

If you are experiencing difficulties with connectivity or audio, you may want to send a message to the system that you are managing.

Only the near site can see the message; it is not broadcast to all parties in a call.

To send a message via the VSX web interface:

1. Go to **Utilities > Send a Message**.
2. In the Send a Message page, enter a message (up to 100 characters in length), then click **Send Message**.

The message is displayed for 15 seconds on the screen of the system that you are managing.

System Screens Quick Reference

To view information about the system, go to the **Home** screen and select **System**. Then choose the type of information you need:

This choice:	Presents this information or capability:
Admin Settings	User interface customization, system customization, security, dialing requirements and network configuration, key-enabled options, Global Management System information
Diagnostics	System status and performance, system tests
System Information	Identifying information
User Settings	System behavior and appearance

Diagnostic Screens

You can view network statistics and perform diagnostic tests from the VSX system's **Diagnostics** screens.

>> Go to **System > Diagnostics**.

You can also view statistics and run the same diagnostic tests from the VSX web interface:

1. Open a web browser on your computer.
2. Enter the system's IP address, for example, `http://255.255.255.255`.
3. Enter the user name and administrator's password, if a password has been established.
4. Click **Diagnostics** from any page to access the following diagnostic tools:
 - **System Status** – provides details of all connections to the system, including ISDN and IP Network connections
 - **Call Statistics** – provides information about the call status, bit rates, formats, protocols, and call summary.
 - **Network** – provides diagnostic tools to test network connectivity.
 - **Video** – provides a color bar pattern for testing your monitor's color settings.
 - **Audio** – provides access to the Speaker Test and Audio Meter screens.
 - **Reset System** – restores software to original factory and installation settings.

System Status Tools

>> Go to **System > Diagnostics > System Status** to see the **System Status** and **Call Summary** screens.

The Home screen has a status notification area that advises of any changes in or potential issues with the status of the system. Select any alert shown in this area to open to the System Status page.

The System Status screen

The System Status screen shows icons for an at-a-glance indication of the system's network connections and time server connections, and other status information.

The icons provide the various connections and system settings.

To see a detailed explanation of the status of a particular item:

>> Select the item with the remote control and press  or .

The Call Summary screen

This screen provides information about system usage, including:

- The duration of the last call
- The number of calls the system has made and received
- The total duration of all calls the system has made and received
- Total numbers of IP and ISDN calls
- Percentages of calls that were IP calls, and that were ISDN calls

This screen is also accessible from the Call Statistics area.

Call Statistics Tools

>> Go to **System > Diagnostics > Call Statistics** to access the **Call Status** and **Call Statistics** screens.

The Call Status screen

The **Call Status** screen displays the call type — IP (H.323) or ISDN (H.320) — data speed, and number dialed for the current call. In addition, this screen displays the number of channels used if the system is in an ISDN call, and the connection status for each channel. If a channel fails to connect, you can select its call progress indicator to see the number for that channel. This can help you or your ISDN service provider diagnose the problem.

The Call Statistics screens

These screens display information about what the system is transmitting and receiving. Information on the first Call Statistics page includes call speed, audio and video protocols, annexes, and error count. Information on the second Call Statistics page includes the audio and video rates specified for the call, the video rate used, and the video frame rate used.

Both Call Statistics screens include the far site system's name, system type, IP address or ISDN number, and call type.

If the unit is using the internal multipoint option, the Call Statistics screen shows all of the above details for all of the sites in the call.

Network Tools

The Network Diagnostics screen provides access to the Near End Loop and PING tests. These allow you to determine whether your system is able to make IP calls successfully.

>> Go to **System > Diagnostics > Network**.

This screen lets you choose the Near End Loop test or the PING test.

The Near End Loop test

The Near End Loop test lets you see how the far site would see and hear you.

This test is not available when you are in a call.

1. On the **Network Diagnostics** screen, select **Near End Loop** to start the test. Monitor 1 displays the video that would be sent to the far site in a call.
2. Press any button on the remote control to stop the loop.

The PING Screen

The PING screen allows you to test whether the system can establish contact with a far-end IP address that you specify.

This test is not available when you are in an IP call, and it is not available from the Web interface.

>> On the **Network Diagnostics** screen, select **PING**.

To PING another system:

1. Enter the IP address that you wish to test.
2. Select **Start**. If the test is successful, the system displays a message indicating that the IP address under test is H.323 enabled.

Video Tool

The Video Diagnostics screen allows you to test the color settings of your monitor for optimum picture quality. If the color bars generated during the test are not clear, or the colors do not look correct, the monitor needs to be adjusted.

1. Go to **System > Diagnostics > Video**.
2. Select the **Color Bars** icon to display the color bars test screen.
3. With the color bars test screen displayed, adjust the color settings on the monitor.
4. To exit the **Color Bars** screen and return to the **Video Diagnostics** screen, press any button on the remote control.

Audio Tools

>> Go to **System > Diagnostics > Audio** to access the Audio Diagnostics screens.

The Speaker Test screen

The Speaker Test screen tests the audio cable connections. A 400 Hz audio tone indicates that the local audio connections are correct.

If you are in a call, the far site will also hear the tone.

1. Go to **System > Diagnostics > Audio > Speaker Test**.
2. Select the **Speaker Test** icon to hear the audio tone.
3. Press any button on the remote control to stop the tone.

If you do not hear a tone, check the audio cable connections and volume of the VSX system, and the TV monitor or speaker system.



If you start the Speaker Test from the VSX web interface, the people at the site you are testing will hear the tone, but you will not. You can send a message to tell them how to notify you if they do not hear the speaker test.

The Audio Meter screen

The Audio Meter screen measures the strength of audio signals from:

- The microphone pod(s)
- Far site audio
- VCR/DVD audio

In the event of audio problems, the Audio Meter screen can help you to determine the cause.

To access the Audio Meter screen:

>> On the **Audio Diagnostics** screen, select **Audio Meter**.

To check audio levels:

1. Microphones: Speak into the microphone.
2. Audio Line In White and Audio Line In Red: Play audio into the system using the device connected to the audio inputs.
3. Far Site Audio: Ask a participant at the far site to speak.
4. Connect a VCR/DVD to the VCR/DVD inputs.
5. Play the VCR/DVD to test audio.

The audio meter should register between 0 and 15 dB for each active input. If it does not, take the appropriate corrective action:

- Microphone pod – check that the conference link cable is seated properly at both ends, and move the microphone pod closer to the person who is speaking.
- Audio input (red or white) – check that the audio cable connectors are all seated properly, and adjust the volume.
- Far Site Audio – Ask far site participants to check the microphone connections, or to move the microphone closer to the person who is speaking.
- Check that the VCR/DVD audio input cables are connected properly.

The Reset System Screen

>> Go to **System > Diagnostics > Reset System** to access the **Reset System** screen.

The Reset System screen clears existing system configurations, including your administrative password and user settings. You can also choose to delete the System settings and Directory entries.

To reset the system:

1. On the **Reset System** screen, enter the system's serial number.
The system will not reset if you do not enter the correct serial number.
2. Specify whether to delete System Settings and Directory entries.



If you do not delete System Settings and Directory entries, system reset will only delete the admin password and the user settings.

If you choose to remove system settings during the reset, the setup wizard will lead you through the initial configuration again.

If you choose to delete Directory entries, only the entries in your local Directory will be deleted. System reset does not affect the Global Directory.

3. Select the **Reset System** icon to begin the reset process.

General Troubleshooting

This section presents problems, likely causes, and corrective actions. Problems are presented as follows:

- Critical problems** – prevent use of the system or access to common functions.
- Severe problems** – prevent you from making calls successfully.
- Minor issues** – detract from the user experience.

Critical Problems

Symptom	Cause	Solution
System does not respond in any way.	The power switch is in the OFF position.	Turn on the power switch.
	The system is not connected to a power source.	Make sure all cables are connected correctly. Make sure that the system is connected to the subwoofer and that the subwoofer is connected to a power outlet. The power for the system is supplied by the subwoofer, so it must be connected in order for the system to work.
	The power outlet is not active.	Check the power outlet by disconnecting the subwoofer's power cord and plugging in a lamp, radio, or other small appliance. If it does not operate, connect the subwoofer to a different outlet.
	The subwoofer's power supply is not operating properly.	Check the power outlet by disconnecting the subwoofer's power cord and plugging in a lamp, radio, or other small appliance. If it operates, the problem is in the subwoofer or the system. Call Polycom Technical Support and arrange to return the system components for service.
System starts in the Software Update screen.	System software is corrupt or not loaded properly.	Load system software from your PC. For instructions on how to do this, refer to Keeping your Software Current on page 49 or consult your network equipment provider.

Symptom	Cause	Solution
System does not respond to the remote control.	No batteries in the remote control.	Install batteries in the remote control.
	Batteries are installed incorrectly in the remote control.	Insert batteries in the correct +/- position.
	The room lights operate in the 38 KHz range and interfere with the remote control signals.	Try turning off the lights in the room and try the remote control again.
	Infrared sensor is not receiving signals from the remote control.	Make sure the transparent protective strip has been removed from the infrared sensor on the front of the VSX 7000 set-top. Make sure you are pointing the remote control at the infrared sensor.

Severe Problems



Symptom	Cause	Solution
Error message occurs when placing a call.	H.320 (ISDN) call: The first line did not connect. The system cannot make a call if the first line does not connect.	<p>Be sure you are calling the correct number. The number may need to include:</p> <ul style="list-style-type: none"> • a digit for an outside line • a long distance access code • an international access code • a country code • an area code or city code <p>Check that all network cables are properly connected.</p> <p>Power off the system, wait five seconds, and power on the system. Then wait about two minutes to allow the ISDN lines to resynchronize.</p> <p>Ask the person at the far end to call your system.</p>
	H.320 (ISDN) call: The ISDN switch type is not configured correctly on the VSX system.	Check the ISDN configuration and verify with your ISDN network service provider that the system is configured correctly.
	H.323 (IP) call: The system is not connected to the LAN.	<p>Verify that the LAN cable is connected properly.</p> <p>Replace the LAN cable.</p>
	H.323 (IP) call: The far site is not connected.	Use the PING test (System > Diagnostics > Network > PING) to determine whether the far site is accessible to your system. If the test fails, the far site system is unavailable.
	H.323 (IP) call: The system is not configured correctly for the network.	Check your IP configuration.
	H.323 (IP) call: The IP Gateway/Gatekeeper is not operating or is not configured correctly.	Contact your network administrator.

Symptom	Cause	Solution
ISDN: Line Status icons do not go away so video calls cannot be made.	The system is not connected to an ISDN network.	Check the ISDN line connections.
	The ISDN number is entered incorrectly.	Check the ISDN numbers with your service provider.
	The SPID numbers are entered incorrectly. Note: The AT&T point-to-point protocol does not require SPIDs.	Select the Clear icon on the Auto Detect SPIDs page, and then select the Start icon to automatically detect the new SPIDs. Make sure your ISDN numbers are entered correctly.
	The Quad BRI network interface module is directly connected to a U interface.	Install an NT-1 device between your network interface module and the ISDN connection.
	The system is connected to an NT-1 then to a PBX.	You do not need an NT-1 device when connecting to a PBX. Connect the system directly to the PBX S/T connection.
	The ISDN line is provisioned incorrectly by the ISDN network service provider.	Check that your ISDN line is provisioned for Voice/Data, Voice/Data.
	The system was not able to auto-detect SPIDs.	Check with your ISDN service provider and enter the SPIDs and switch protocol manually. Note: The AT&T point-to-point protocol does not require SPIDs.
	The VSX system is in an unknown state.	Power off the system, wait five seconds, and power on the system.
ISDN: Error message when dialing a video call.	An ISDN cause code is received from the ISDN line.	Try the call again. For more information, please refer to Q.850 Cause Codes on page 8 .
ISDN: When placing a call, progress indicators do not turn green.	The call progress icons do not turn green to indicate that the call connected properly.	Try the call again.
The System Information screen shows “waiting” in the IP Video Number field.	The LAN is not working.	Check the LAN connection. Contact your network administrator.
	The DHCP server is not available.	Contact your network administrator to correct the problem with the server or to assign a static IP address.

Symptom	Cause	Solution
Cannot dial remote system in BONDING 384 K calls. (The call progress circles only show blue or yellow.)	Switch protocol issue.	Start by calling the far site at 1x56, 1x64, 2x56, or 2x64K, as appropriate. This will verify the primary number. If these calls complete, try 256K, then 384K. Being able to dial non-bonded but unable to dial bonded to all locations is usually a switch protocol issue. Verify your ISDN provisioning with the telephone service provider.
Dialing a remote site in calls above 128 K does not work. (The Call Progress circles do not turn green, or remain blue after the first channel connects.)	The far site may be unable to accept calls above 128 K.	Go to the Call Status screen. Highlight each of the circles for each of the channels dialed. The number dialed for each channel will be displayed as you highlight the corresponding circle. Make sure that the far site has entered the number for each of its ISDN lines correctly. The numbers for Line 1 - Line 4 should correspond to connections 1 - 4 on the Quad BRI network interface module.
Cannot select 112 or 128 speeds for BONDING calls from the speed selection.	Speeds do not show when selecting the speed icon.	Add line speeds on the Admin Settings > Video Network > Call Quality > Dialing Speeds screen.
No audio in a call.	The far site is muted.	Look for the far site Mute icon. Ask the far site to unmute the microphone.
	The monitor's audio inputs are not connected properly.	Check audio output using the Speaker Test screen under Diagnostics > Audio . You should hear a 400 Hz tone. Ask someone at the far site to speak into the microphone, and check the Far Site Audio meter on the Audio Meter screen under Diagnostics > Audio to determine whether your system is receiving audio.
The people at the far site cannot hear you.	No power to near site microphone pod.	Check the conference link cable. Replace the subwoofer - there is a problem with the power supply.
One or more system components do not operate properly.	The components are not powered on.	Verify that components' power cords are connected to power outlets, and that they have been powered on.
	The components are not connected properly.	Verify that the cables are connected correctly according to the installation procedures in Setting Up the System on page 19 .

Minor Issues

Symptom	Cause	Solution
Not enough volume during a call.	The volume is set too low on the system.	Turn up the volume using the remote control.
	The volume is set too low on the monitor.	Turn up the volume on your monitor or external audio system.
	The microphone pod is too far from the people speaking.	Place the microphone pod between the monitor and the person closest to the monitor.
Startup music plays through the built-in VSX 7000 speaker but not through the monitor speakers.	The audio system or monitor speakers are not properly connected.	Check audio connections and volume level on your monitor.
Incoming call ring and other sound effects too loud or too soft.	The sound effects volume is not set at desired level.	Adjust the sound effects volume on the Audio Settings screen. If you do not want to hear sound effects, set the volume to 0.
An echo is heard at the near site when speaking.	The far site microphone is too close to the audio speaker.	At the far site, make sure the microphone is placed away from the audio speaker.
	The far site audio volume may be too loud.	Turn down the audio volume at the far site.
Picture is blank on the main monitor.	The system goes to "sleep" after a period of inactivity.	Pick up the remote control to wake up the system.
When using two monitors, the same picture is seen on the first and second monitor.	Only one monitor is enabled.	Enable the system for two monitors on the Admin Settings > Monitors screen.
	The monitors are connected to the same output. The monitor has a composite as well as an S-Video output.	Connect Monitor 2 to the Monitor 2 connection on the rear panel of the system.
Graphics are displayed on Monitor 1 at all sites even if Monitor 2 has been specified for content.	At least one site does not have dual-stream capability. This occurs in calls to ViewStation FX systems using version 4.2 and earlier software.	Upgrade to dual-stream capability. ViewStation FX owners can upgrade to software version 5.0.
Picture freezes frequently during an IP call.	There is too much traffic on the LAN. Check the error count on the Call Statistics screen.	Go to Admin Settings > Video Network > IP Network > Quality of Service and enable dynamic bandwidth.

Symptom	Cause	Solution
Picture freezes frequently during an ISDN call.	Too many network line transmission errors. Check the error count on the Diagnostics > Call Statistics screen to verify this.	Try the call again.
	Network interface cable or cables may be bad.	Replace the cable or cables.
Picture is slow or jerky.	Only one 64 Kbps channel is connecting in your call.	Check the ISDN number of the far site. Ask the far site to call your site.
	The system is receiving video that includes a large amount of motion.	A background with less motion provides a better, smoother video picture.
Edges of picture are cut off when viewing graphics	Graphics from the far site are displayed on an NTSC monitor. This problem may occur in multipoint calls using a RADVision MCU.	Use a VGA monitor to display graphics.
Blue screen in the PIP window.	No video input.	Check that there is a video source connected to the selected input.
	The camera selection is incorrect.	Select the appropriate camera: Press  Camera , then press the number of the camera you wish to use.
	The VCR input is selected and the VCR is not running. Most VCRs generate a blue screen when the tape is not playing.	Select a different camera or play a tape on the VCR.
Near-site camera does not pan or tilt.	You are attempting to move a camera that does not have pan/tilt/zoom capabilities.	Make sure you have selected a pan/tilt/zoom camera.
Call participants cannot see or hear what is being played on the VCR or DVD.	The VCR or DVD is not selected.	Select the VCR (Camera 3): Press  Camera , then press 3.
	The VCR or DVD is not set up correctly.	Check that the VCR or DVD is connected according to the instructions in Setting Up the System on page 19 . Refer to the manufacturer's instructions to set up the VCR or DVD correctly.
Low battery icon on the screen.	Low batteries in the remote control.	Replace the batteries in the remote control with 3 AAA batteries.

Symptom	Cause	Solution
Cannot access the system from the VSX web interface.	DHCP Client is ON and no DHCP server is available.	Contact your network administrator.
	The LAN cable is not connected.	Connect the LAN cable to the LAN port on the rear of the system.
	Bad LAN cable.	Check the lights on the back of the system. There should be a steady green light indicating a connection to the LAN, and a flashing orange light indicating LAN traffic.
	There is a firewall between your PC and your system.	Consult your network administrator.
	Your PC is on a different subnet and there is a router between you and your system.	Change your PC or system subnet mask and IP address so that they are both on the same LAN or subnet.
System does not allow management via the VSX web interface.	Wrong password.	Enter the correct user name and password. Note: The default user name is admin , and the default password is the unit's serial number.
	Too many managers are logged into the system.	Only five system managers are allowed at any one time. To log everyone out, restart your system.

Normal System Behaviors

Symptom	Cause	Solution
Screen is blank; start music plays and Polycom logo appears briefly. The lamp on the front of the VSX 7000 blinks, alternating between amber and green.	The system is starting.	This is normal.
The light on the front of the VSX 7000 blinks green when you press any button on the remote control.	The system is not in a call.	This is normal.
The light on the front of the VSX 7000 blinks amber when you press any button on the remote control.	The system is in a call.	This is normal.
Camera turns to the side and the monitor goes blank after displaying the splash screen.	The system is sleeping.	System is in power save sleep mode. The system wakes up on any action from the remote control or on an incoming call.
Amber light appears on the front of the VSX 7000.	The system is in a call.	This is normal.
Green light appears on the front on the VSX 7000.	The system is not in a call.	This is normal.

How to Contact Technical Support

If you are not able to make test calls successfully and you have verified that the equipment is installed and set up correctly, contact Polycom Technical Support by telephone or Internet as described below.

By Telephone

Before calling Polycom Technical Support, please have the following information ready. We also suggest that you go to **System > System Information** so that you will have the **System Information** screen showing when you call for help.

- Description of the issue – What is happening or not happening, and any related events you may be able to notice.
- The 14-digit serial number on the bottom of the system.

Contact Polycom Technical Support at 1-800-POLYCOM.

By Internet

To contact Polycom Technical Support, go to www.polycom.com/support.

Enter the following information, then ask a question or describe the problem. This information helps us to respond faster to your issue:

- The 14-digit serial number in the **System Information** screen (also present on the bottom of the system),
- The software version (from the **Home** screen, select **System > System Information**),
- Information about your network, and
- Troubleshooting steps you have already tried.

Appendix

This appendix provides the following technical details about the VSX system:

- Graphics Displays
- Multipoint Dialing Speed Information
- Cable Descriptions
- Cable Drawings
- Q.850 Cause Codes

Graphics Displays

The following table describes what you see when you share graphics.

If graphics are directed to:	Monitor 1 shows:	Monitor 2 (S-Video or composite) shows:	VGA monitor shows:	Projector shows:	PIP shows:
Monitor 1	Graphics	Near video	None	Graphics	Far video
Monitor 2	Far video	Graphics	Graphics	Graphics	Near video
Projector	Far video	Near video	None	Graphics	None

Multipoint Dialing Speed Information

In a multipoint call, all parties must be connected at the same speed.

The following table shows the maximum allowable dialing speeds for the number of sites, including the main site, in a call.

Network Interface	Number of Sites in a Call	Maximum Speed for Each Party in the Call (Kbps)	
		H.320	H.323
BRI	2 with 2 lines	256	1920
	2 with 3 lines	384	1920
	2 with 4 lines	512	1920
	3 with 2 lines	128	512
	3 with 3 lines	192	512
	3 with 4 lines	256	512
	4 with 2 lines	64	384
	4 with 3 lines	128	384
	4 with 4 lines	128	384
H.323 Only		Refer to H.323 speeds in this table.	

Cable Descriptions

The following table gives information about the cables shipped with the system. Drawings for these cables are included in this appendix.

Cable	Maximum approved length	Part number shipped	Other cables available
LAN cable Orange RJ-45	100 ft (30 m)	2457-08343-001 12 ft (3.6 m)	
Monitor cable S-Video, yellow 4-pin mini-DIN	50 ft (15 m)	2457-08409-001 25 ft (7.6 m)	2457-09204-001 50 ft (15 m)
Conference link cable Brown RJ-9, offset tab	100 ft (30 m)	2457-20910-001 30 ft (9 m)	2457-20910-002 10 ft (3 m)
	—	0.5 ft (0.15 m)	

The table below lists other cables that you may need to be able to use the system's full range of capabilities.

Cable	Maximum approved length
Camera cable (S-Video, yellow 4-pin mini-DIN)	100 ft (30 m)
VGA cable (15-pin high-density subminiature D)	25 ft (7.6 m)
VCR/DVD composite cable (Triple RCA)	50 ft (15 m)
Dual display adapter option, 2457-10849-001	—

Cable Drawings

The following cables are provided with your VSX system:

- LAN cable
- Monitor cable
- Conference link cable

Their pin-outs are shown in the following drawings.

WIRING COLOR CODE STANDARDS: (WIRE/STRIPE)

P1	P2	
PIN #	PIN #	AT&T 258A/268B
1	1	WHITE/ORANGE
2	2	ORANGE/WHITE
3	3	WHITE/GREEN
4	4	BLUE/WHITE
5	5	WHITE/BLUE
6	6	GREEN/WHITE
7	7	WHITE/BROWN
8	8	BROWN/WHITE

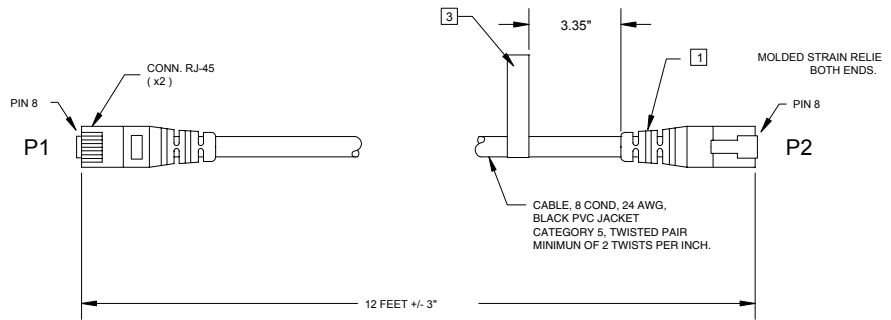

NOTES: (UNLESS OTHERWISE SPECIFIED).

- 1 MOLDING MATERIAL: PVC UL94 V-0
COLOR: ORANGE, APPROXIMATE MATCH TO PANTONE #1665 U.
- 2. APPROVED VENDOR: PAN INTERNATIONAL ELECTRONICS (THAILAND) CO. LTD. (66-2) 5293549-50.
PAN INTERNATIONAL DETAILED SPEC IS IN THE PART FILE.
- 3 THE BARCODE CONTAINS LAST 8 DIGIT OF CABLE PART NUMBER (REMOVE VV2457).
LABEL SPEC : LASER LABEL
SIZE : LABEL SIZE (12 X 76mm)

LAN Cable 2457-08343-001

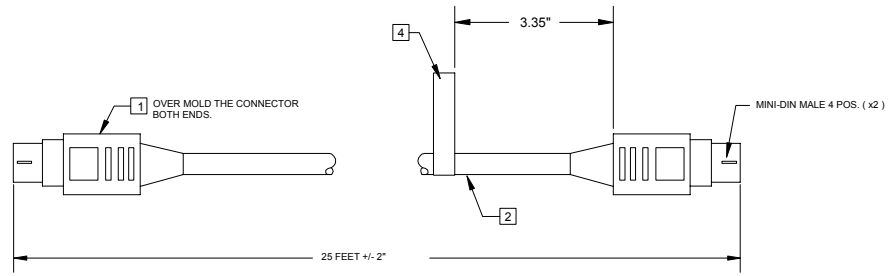

NOTES: (UNLESS OTHERWISE SPECIFIED).

- 1 MOLDING MATERIAL: PVC UL94 V-0
COLOR: YELLOW, APPROXIMATE MATCH TO PANTONE #109C.
- 2 CABLE: COMPOSITE, ROUND MADE UP OF 3 COAXIAL-MINIATURE 75 ohm., 30 AWG, CELLULAR POLYOLEFIN, 90% TINNED COPPER SHIELD, CABLES WITH FILLER FOR ROUNDNESS, JACKET COLOR BLACK, MATTE FINISH.
- 3. APPROVED VENDOR: PAN INTERNATIONAL ELECTRONICS (THAILAND) CO. LTD. (66-2) 5293549-50. PAN INTERNATIONAL DETAILED SPEC IS IN THE PART FILE.
- 4 THE BARCODE CONTAINS LAST 8 DIGIT OF CABLE PART NUMBER (REMOVE VV2457).
LABEL SPEC : LASER LABEL
SIZE : LABEL SIZE (12 X 76mm)

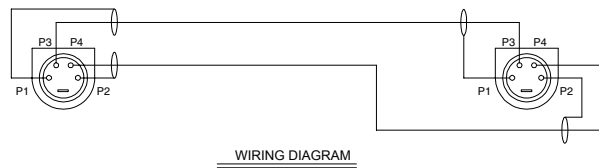

S-Video Cable 2457-08409-001

VSX 7000 Series Administrator's Guide

3	1	FAIR-RITE PN 2681665702 OR POLYCOM APPROVED EQUIVALENT
2	30 FT	FLEXIBLE CABLE, CONSISTING OF TWO 28 AWG, STRANDED TWISTED PAIRS, ONE 24 AWG, STRANDED CONDUCTOR, WITH OVERALL SPIRAL PAPER PLUS TINNED COPPER SHIELD.
1	2	OFFSET TAB RJ11 PLUG, 6P6C, STEWART PIN: 937-SP-3066R-OST OR EQUIVALENT
ITEM	QTY.	DESCRIPTION

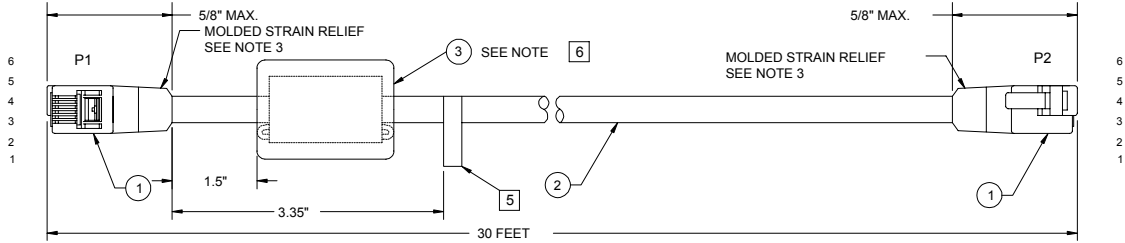

- NOTES:
- CABLE MUST BE UL TYPE CL2 RATED AND MEET UL VW-1 REQUIREMENTS. INCLUDE CERTIFICATE OF COMPLIANCE WITH SHIPMENT. DO NOT MARK CABLE ITSELF.
 - O.D. OF CABLE: 4.0MM MAX.
 - MOLDING MATERIAL: PVC UL94 V-0
COLOR: BROWN, APPROXIMATE MATCH TO PANTONE #497 U.
 - TIE DIAMETERS TO MINIMIZE CURL
 - BARCODE LABEL TO CONTAIN LAST 8 DIGITS OF CABLE PART NO. (REMOVE 2457).
CABLE SPEC: LASER LABEL
SIZE: 12mm X 76mm
 - OVERMOLD ITEM 3, FERRITE CORE. POSITION FERRITE 1.5 INCHES FROM CONNECTOR AND WRAP THE CABLE ONE TURN AROUND THE FERRITE CORE PRIOR TO OVERMOLDING.

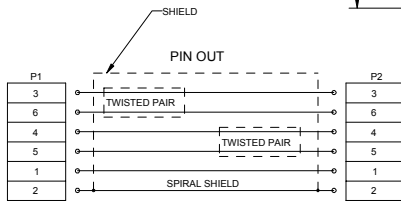
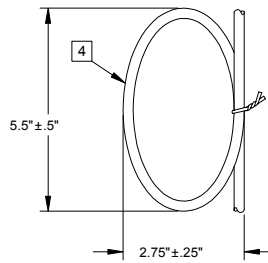

Conference Link Cable 2457-20910-001, 30 ft (9 m)

2	10 FT	FLEXIBLE CABLE, CONSISTING OF TWO 28 AWG. STRANDED TWISTED PAIRS, ONE 24 AWG. STRANDED CONDUCTOR, WITH OVERALL SPIRAL PAPER PLUS TINNED COPPER SHIELD.
1	2	OFFSET TAB RJ11 PLUG, 6P6C, STEWART P/N: 937-SP-3068R-OST OR EQUIVALENT
ITEM	QTY.	DESCRIPTION

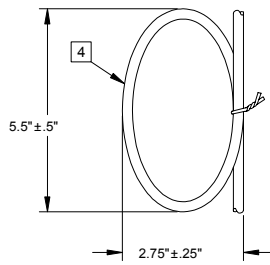
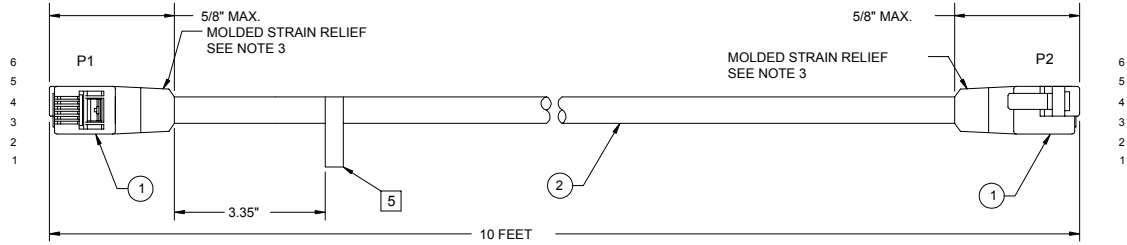

- NOTES:
1. CABLE MUST BE UL TYPE CL2 RATED AND MEET UL VW-1 REQUIREMENTS. INCLUDE CERTIFICATE OF COMPLIANCE WITH SHIPMENT. DO NOT MARK CABLE ITSELF.
 2. O.D. OF CABLE: 4.0MM MAX.
 3. MOLDING MATERIAL: PVC UL94 V-0
COLOR: BROWN, APPROXIMATE MATCH TO PANTONE #497 U.
 - 4 TIE DIAMETERS TO MINIMIZE CURL
 - 5 BARCODE LABEL TO CONTAIN LAST 8 DIGITS OF CABLE PART NO. (REMOVE 2457).
CABLE SPEC: LASER LABEL
SIZE: 12mm X 76mm

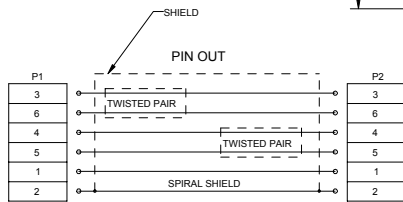

Conference Link Cable 2457-20910-002, 10 ft (3 m)

Q.850 Cause Codes

The following table describes codes that the ISDN switch sends to the router to indicate call status. Although the codes are standardized, each ISDN service provider defines them differently. Because of this, the definitions in the table may not exactly match the messages that you see.

Code	Cause	Definition
1	Unassigned number	The switch received the sent ISDN number in the correct format, but no destination equipment uses the number.
2	No route to specified transit network	The ISDN exchange does not recognize the intermediate network through which to route the call.
3	No route to destination	The intermediate network through which the call is routed does not serve the destination address.
6	Channel unacceptable	The specified channel does not provide adequate service quality to accept the requested connection.
7	Call awarded and delivered	The user is assigned an incoming call that is being connected to a call channel that has already been established for this user and this type of call.
16	Normal call clearing	The originator or receiver of the call has requested that it be cleared.
17	User busy	All B channels are in use; the called system acknowledges the connection request, but is unable to accept the call.
18	No user responding	The destination equipment does not respond to the call, so the connection cannot be completed.
19	No answer from user (user alerted)	The destination equipment did not complete the connection within the prescribed time after responding to the connection request. The problem is at the remote end of the connection.
21	Call rejected	The destination equipment is capable of accepting the call, but has rejected it for an unknown reason.
22	Number changed	The ISDN number used to set up the call is no longer valid. (The diagnostic field of the message may return an alternate address assigned to the called equipment.)
26	Non-selected user clearing	The destination is capable of accepting the call, but did not assign it to the user.
27	Destination out of order	A signaling message cannot be delivered because the interface is not functioning correctly, and the destination cannot be reached. This condition might be temporary; for example, remote equipment might be turned off.

Code	Cause	Definition
28	Invalid number format	Destination address was incomplete or presented in an unrecognizable format, which prevented the connection from being established.
29	Facility rejected	The network cannot provide the facility requested by the user.
30	Response to STATUS INQUIRY	The equipment returns this message when it receives a STATUS INQUIRY message.
31	Normal, unspecified	A normal event has occurred with no standard cause applying. No resulting action is required.
34	No circuit/channel available	The call cannot be taken because no appropriate channel is available to establish the connection.
38	Network out of order	A network problem prevented the call from reaching its destination. Attempts to reconnect will probably fail until the network problem is corrected.
41	Temporary failure	A network error occurred. The problem will be resolved shortly. Attempts to reconnect may succeed.
42	Switching equipment congestion	The destination cannot be reached because the network switching equipment is temporarily overloaded.
43	Access information discarded	The requested access information cannot be provided by the network. The diagnostic message may explain the problem.
44	Requested circuit/channel not available	The remote equipment cannot provide the requested channel. This may be temporary.
47	Resource unavailable, unspecified	An unknown problem prevents the remote equipment from providing the requested resource.
49	Quality of service unavailable	The network cannot provide the requested quality of service (as defined by CCITT recommendation X.213). This may be a subscription problem.
50	Requested facility not subscribed	The remote equipment is capable of providing the requested supplementary service, but is not subscribed to it.
57	Bearer capability not authorized	The caller has requested a bearer capability that the network can provide, but the user is not authorized to use. This may be a subscription problem.
58	Bearer capability not presently available	The network normally provides the requested bearer capability, but cannot provide it now. This may be a temporary network problem or a subscription problem.
63	Service or option not available, unspecified	An unspecified problem prevents the network or remote equipment from providing the requested service or option. This might be a subscription problem.

Code	Cause	Definition
65	Bearer capability not implemented	The network is not capable of providing the bearer capability requested by the user.
66	Channel type not implemented	The requested channel type is not supported by the equipment sending this code.
69	Requested facility not implemented	The remote equipment is not capable of providing the requested supplementary service.
70	Only restricted digital information bearer is available	The network is unable to provide unrestricted digital information over bearer capability.
79	Service or option not available, unspecified	The network or remote equipment is unable to provide the requested service option for an unspecified reason. This might be a subscription problem.
81	Invalid call reference value	The remote equipment received a call with a call reference that is not currently in use on the user-network interface.
82	Identified channel does not exist	The receiving equipment is requested to use a channel that is not activated on the interface for calls.
83	A suspended call exists but this call identity does not	The network received a call resume request that contained a call identity information element that does not match any suspended call.
84	Call identity in use	The network received a call suspend request that contained a call identity information element for a call that is already suspended.
85	No call suspended	The network received a call resume request when there was not a suspended call pending. This might be a transient error that will be resolved by successive call retries.
86	Call having requested call identity has been cleared	The network received a call resume request containing a call identity information element for a call that was cleared while suspended, either by timeout or by the remote user.
88	Incompatible destination	Indicates that an attempt was made to connect to non-ISDN equipment, such as an analog line.
91	Invalid transit network specified	The ISDN exchange was asked to route the call through an unrecognized intermediate network.
95	Invalid message, unspecified	An invalid message was received, for an unknown reason. This is usually due to a D-channel error. If this error occurs systematically, report it to your ISDN service provider.
96	Mandatory information element is missing	The equipment received a message that did not include one of the mandatory information elements. This is usually due to a D-channel error. If this error occurs systematically, report it to your ISDN service provider.

Code	Cause	Definition
97	Message type nonexistent or not implemented	The equipment received a message of a type that is invalid or not supported. This code indicates either a problem with the remote configuration or a problem with the local D channel.
98	Message incompatible with call state or message type nonexistent	The equipment received a message that is not valid in the current call state. Cause 98 is usually due to a D-channel error. If this error occurs systematically, report it to your ISDN service provider.
99	Information element nonexistent or not implemented	The equipment received a message that includes information elements which were not recognized. This is usually due to a D-channel error. If this error occurs systematically, report it to your ISDN service provider.
100	Invalid information element contents	The equipment received a message that includes invalid information in the information element. This is usually due to a D-channel error.
101	Message not compatible with call state	The remote equipment received a message that does not correspond to the current state of the connection. This is usually due to a D-channel error.
102	Recovery on timer expiry	A time-out has triggered an error-handling (recovery) procedure. This problem is typically temporary.
111	Protocol error, unspecified	An unspecified D-channel error when no other standard cause applies.
127	Interworking, unspecified	An event occurred within a network that does not provide causes for the action that it takes. The precise problem is unknown.
145	ISDN layer 1 and/or 2 link not established	User needs to check cabling, ISDN adapter status and network connections.
146	ISDN layer 3 connection to the ISDN switch/network inactive	There is either a switch protocol error, or (in the United States or Canada) a SPID assignment problem.
255	ISDN command processing error	The ISDN signaling code has encountered an error processing an ISDN action. ISDN adapter busy-wait and retry.

Safety and Legal Notices

Important Safeguards

Read and understand the following instructions before using the system:

- Close supervision is necessary when the system is used by or near children. Do not leave unattended while in use.
- Only use electrical extension cords with a current rating at least equal to that of the system.
- Always disconnect the system from power before cleaning and servicing and when not in use.
- Do not spray liquids directly onto the system when cleaning. Always apply the liquid first to a static free cloth.
- Do not immerse the system in any liquid or place any liquids on it.
- Do not disassemble this system. To reduce the risk of shock and to maintain the warranty on the system, a qualified technician must perform service or repair work.
- Connect this appliance to a grounded outlet.
- Only connect the system to surge protected power outlets.
- Keep ventilation openings free of any obstructions.
- SAVE THESE INSTRUCTIONS.

License Restrictions

THE SOFTWARE PROGRAMS CONTAINED OR DESCRIBED HEREIN ARE CONFIDENTIAL INFORMATION AND PROPRIETARY PRODUCTS OF POLYCOM, INC. OR ITS LICENSORS.

Buyer shall not sublicense or otherwise distribute any of the Subject Programs except to End Users and/or resellers who have entered into a Sublicense Agreement. For purposes of this Agreement a "Sublicense Agreement" shall mean a written license agreement between the Buyer and its purchaser, or, in the case of any sale by Buyer to a reseller, between such reseller and the End User, that is either 1) signed by the End User or 2) included with the Documentation, in such a manner that the End User reasonably indicates its acceptance of the Sublicense Agreement by turning on and using the Computer Equipment. Polycom, Inc. shall include so-called "break the seal software licenses" with the Documentation, and Buyer shall not remove or alter any such Sublicense Agreements or any notifications or warning stickers relating thereto. Buyer shall not waive, amend, or otherwise modify any Sublicense Agreement without Polycom's prior consent.

Title to all Subject Programs shall at all times remain and vest solely with Polycom, Inc. and its licensors. Buyer acknowledges Polycom's claim that the Subject Programs are its trade secret and confidential property, and shall treat them as such. Buyer will not attempt to disassemble, decompile, reverse-engineer or otherwise endeavor to discover or disclose the methods and concepts embodied in the Subject Programs. Except as expressly allowed under this Agreement, the Buyer shall not copy, modify, transcribe, store, translate, sell, lease, or otherwise transfer or distribute any of the Subject Programs in whole or in part, without prior authorization, in writing, from Polycom, Inc. Buyer shall not remove or destroy any copyright, patent, trademark or other proprietary mark or notice on Computer Equipment, and shall reproduce any such marks on any copies of Subject Programs that it makes hereunder.

You shall not, and shall not allow, any third party to 1) decompile, disassemble, or otherwise reverse-engineer or attempt to reconstruct or discover any source code or underlying ideas or algorithms of the software by any means whatsoever or 2) remove any product.

Warranty

Polycom, Inc. warrants its products to be free of defects in materials and factory workmanship for a period of twelve (12) months from date of purchase. This warranty does not apply to damage to products resulting from accident, misuse, service or modification by anyone other than a Polycom, Inc. authorized service facility/dealer. The warranty is limited to the original purchaser and is not transferable. Any liability of Polycom, Inc. or its suppliers with respect to the product or the performance thereof under any warranty, negligence, strict liability or other theory will be limited exclusively to product repair or replacement as provided above. Except for the foregoing, the product is provided "as is" without warranty of any kind including without limitation, any warranty of merchantability or fitness for a particular purpose. The entire risk of the quality and performance of the software programs contained in the system is with you.

Limitation of Remedies and Damages

Polycom, Inc., its agents, employees, suppliers, dealers and other authorized representatives shall not be responsible or liable with respect to the product or any other subject matter related thereto under any contract, negligence, strict liability or other theory for any indirect, incidental, or consequential damages, including, but not limited to loss of information, business, or profits.

The law of certain states or nations does not permit limitation or exclusion of implied warranties and consequential damages, so the above limitations, disclaimers, or exclusion may not apply to you. This warranty gives you special legal rights. You may also have other rights that vary by state and nation.

Warning

This is a Class A product. In a domestic environment, this product may cause radio interference in which case the user may be required to take adequate measures.

USA and Canadian Regulatory Notices

FCC Notice

Class A Digital Device or Peripheral

This equipment has been tested and found to comply with the limits for a Class A digital device, pursuant to Part 15 of the FCC Rules. These limits are designed to provide reasonable protection against harmful interference when the equipment is operated in a commercial environment. This equipment generates, uses, and can radiate radio frequency energy and, if not installed and used in accordance with the instruction manual, may cause harmful interference to radio communications. Operation of this equipment in a residential area is likely to cause harmful interference in which case the user will be required to correct the interference at his own expense.

In accordance with Part 15 of the FCC rules, the user is cautioned that any changes or modifications not expressly approved by Polycom Inc. could void the user's authority to operate this equipment.

The socket outlet to which this apparatus is connected must be installed near the equipment and must always be readily accessible.

Part 15 FCC Rules

This device complies with part 15 of the FCC rules. Operation is subject to the following two conditions:

- 1) This device may not cause harmful interference, and
- 2) this device must accept any interference received, including interference that may cause undesired operation.

Part 68 FCC Rules

This equipment complies with part 68 of the FCC rules and the rules adopted by the ACTA. On the Network Interface Module of this equipment is a label that contains, among other information, a product identifier in the format US:AAAEQ#TVSX 7000. If requested, this number must be provided to the telephone company.

This equipment may not be used on a coin service or party line.

If you experience trouble with your VSX 7000, disconnect it from the telephone line to determine if the registered equipment is malfunctioning. For repair or warranty information, please contact Polycom Inc. at 1-888-248-4143 or 4750 Willow Road, Pleasanton, CA 94588-2708, USA. Contact information may also be found at <http://www.polycom.com>. If the system is causing harm to the network, the telephone company may request that you disconnect it until the problem is corrected.

If your VSX 7000 causes harm to the telephone network, the telephone company will notify you in advance that temporary discontinuance of service may be required. However, if advance notice is not practical, you will be notified as soon as possible. You will be advised of your right to file a complaint with the FCC if you believe it is necessary.

Your telephone company may make changes in its facilities, equipment, operations, or procedures that could affect the operation of your equipment. If they do, you will be given advance notice so that you may make any changes necessary to maintain uninterrupted service.

The REN is useful to determine the quantity of devices that may be connected to the telephone line. Excessive RENs on the telephone line may result in the devices not ringing in response to an incoming call. In most, but not all areas, the sum of RENs of all devices that may be connected to a line, is determined by the total RENs, contact the local telephone company.

FCC compliant telephone cords and modular plugs are provided with this equipment. This equipment is designed to be connected to the telephone network or premises' wiring using a compatible modular jack, which is Part 68 compliant. See installation instructions for details.

WHEN PROGRAMMING EMERGENCY NUMBERS AND/OR MAKING TEST CALLS TO EMERGENCY NUMBERS:

- 1) Remain on the line and briefly explain to the dispatcher the reason for the call.
- 2) Perform such activities in the off-peak hours, such as early morning or late evening.

Industry Canada (IC)

This Class [A] digital apparatus complies with Canadian ICES-003.

Cet appareil numérique de la Classe [A] est conforme à la norme NMB-003 du Canada.

The Industry Canada label identifies certified equipment. This certification means that the equipment meets telecommunications network protective, operational and safety requirements as prescribed in the appropriate Terminal Equipment Technical Requirements document(s). The Department does not guarantee the equipment will operate to the user's satisfaction.

Before installing this equipment, users should ensure that it is permissible to be connected to the facilities of the local telecommunications company. The equipment must also be installed using an acceptable method of connection. The customer should be aware that compliance with the above conditions may not prevent degradation of service in some situations. Repairs to certified equipment should be coordinated by a representative designated by the supplier. Any repairs or alterations made by the user to this equipment, or equipment malfunctions, may give the telecommunications company cause to request the user to disconnect the equipment.

Users should ensure for their own protection that the electrical ground connections of the power utility, telephone lines and internal metallic water pipe system, if present, are connected together. This precaution may be particularly important in rural areas.

Caution: Users should not attempt to make such connections themselves, but should contact the appropriate electric inspection authority, or electrician, as appropriate.

The Ringer Equivalence Number (REN) assigned to each relevant terminal device provides an indication of the maximum number of terminals allowed to be connected to a telephone interface. The termination on an interface may consist of any combination of devices subject only to the requirement that the sum of the RENs of all the devices does not exceed 5.

The REN of this equipment is either marked on the unit or included in the new style USA FCC registration number. In the case that the REN is included in the FCC number, the user should use the following key to determine the value:

- The FCC number is formatted as US:AAAEQ#TXXX.
- # is the Ringer Equivalence Number without a decimal point (e.g. REN of 1.0 will be shown as 10, REN of 0.3 will be shown as 03). In the case of a Z ringer, ZZ shall appear. In the case of approved equipment without a network interface or equipment not to be connected to circuits with analog ringing supplied, NA shall appear.

EEA Regulatory Notices

CE Mark R & TTE Directive

This VSX 7000 has been marked with the CE mark. This mark indicates compliance with EEC Directives 89/336/EEC, 73/23/EEC 1999/5/EC. A full copy of the Declaration of Conformity can be obtained from Polycom Ltd., 270 Bath Road, Slough UK SL1 4DX.

Declaration of Conformity:

Hereby, Polycom Ltd. declares that this VSX 7000 is in compliance with the essential requirements and other relevant provisions of Directive 1999/5/EC.

Konformitetserklæring:

Hermed erklærer Polycom Ltd., at indestående VSX 7000 er i overensstemmelse med de grundlæggende krav og de relevante punkter i direktiv 1999/5/EF.

Konformitätserklärung:

Hiermit erklärt Polycom Ltd., dass der VSX 7000 die grundlegenden Anforderungen und sonstige maßgebliche Bestimmungen der Richtlinie 1999/5/EG erfüllt.

Δήλωση Συμμόρφωσης:

Δια του παρόντος, η εταιρεία Polycom Ltd. δηλώνει ότι η παρούσα συσκευή (δρομολογητής) VSX 7000; πληροί τις βασικές απαιτήσεις και άλλες βασικές προϋποθέσεις της Οδηγίας 1999/5/EK.

Vaatimustenmukaisuusvakuutus:

Polycom Ltd. vakuuttaa täten, että VSX 7000 on direktiivin 1999/5/EC keskeisten vaatimusten ja sen muiden tältä koskevien säännösten mukainen.

Déclaration de conformité:

Par la présente, Polycom Ltd. déclare que ce VSX 7000 est conforme aux conditions essentielles et à toute autre modalité pertinente de la Directive 1999/5/CE.

Dichiarazione di conformità:

Con la presente Polycom Ltd. dichiara che il VSX 7000 soddisfa i requisiti essenziali e le altre disposizioni pertinenti della direttiva 1999/5/CE.

Verklaring van overeenstemming:

Hierbij verklaart Polycom Ltd. dat diens VSX 7000 voldoet aan de basisvereisten en andere relevante voorwaarden van EG-richtlijn 1999/5/EG.

Declaração de Conformidade:

Através da presente, a Polycom Ltd. declara que este VSX 7000 se encontra em conformidade com os requisitos essenciais e outras disposições relevantes da Directiva 1999/5/CE.

Declaración de conformidad:

Por la presente declaración, Polycom Ltd. declara que este VSX 7000 cumple los requisitos esenciales y otras cláusulas importantes de la directiva 1999/5/CE.

Överensstämmelseförklaring:

Polycom Ltd. förklarar härmed att denna VSX 7000 överensstämmer med de väsentliga kraven och övriga relevanta stadganden i direktiv 1999/5/EG.

CE Mark LVD and EMC Directive

This VSX 7000 has been marked with the CE mark. This mark indicates compliance with EEC Directives 89/336/EEC and 73/23/EEC. A full copy of the Declaration of Conformity can be obtained from Polycom Ltd., 270 Bath Road, Slough UK SL1 4DX, UK.

Mains Powered POTS Voice Telephony Without Emergency 000 Dialing

Warning: This equipment will be inoperable when mains power fails.

この装置は、情報処理装置等電波障害自主規制協議会（VCCI）の基準に基づくクラスA情報技術装置です。この装置を家庭環境で使用すると電波妨害を引き起こすことがあります。この場合には使用者が適切な対策を講ずるよう要求されることがあります。

Underwriters Laboratories Statement

The system is intended to be powered only by the supplied power supply unit.

Special Safety Instructions

Follow existing safety instructions and observe all safeguards as directed.

Installation Instructions

Installation must be performed in accordance with all relevant national wiring rules.

Plug Acts as Disconnect Device

The socket outlet to which this apparatus is connected must be installed near the equipment and must always be readily accessible.

A

- access
 - limiting 71
 - remote 103
- access levels
 - administrators 52
 - advanced users 52
 - new users 52
- accessories 60
- acoustics 18
- adding
 - directory entries 71
 - site buttons 67
- additional camera 12, 27
- additional microphone pods 14, 18, 23, 25
- additional monitor 12, 14, 26
- address
 - gatekeeper 16, 34
 - IP 16, 31, 99
 - ISDN 16
- adjusting
 - bass 62
 - treble 62
- Admin Settings 53
- administrator password 53, 73, 95, 103
- alert tones 61, 69
- allowing
 - access to directory 65
 - directory updates 55, 71
 - IP calls 31, 33
 - ISDN calls 39
 - mixed calls 55, 70
 - multipoint calls 65
 - remote access 73
- area code 74
- Asian fonts, displaying 23
- audio
 - configuring 61
 - data rate 79
 - diagnostics 93, 94, 100
 - feedback, preventing 21
 - inputs 61
 - meter 94, 100
 - protocol 79, 91

- quality 10, 21, 101
- subwoofer 62
- system 13, 14
- troubleshooting 94, 100, 101
- volume 62, 101

- audio confirmation, keypad 54, 71
- auto-answer 70, 73
 - muting 54
- auto-detecting
 - ISDN connectivity 39
 - SPIDs 40, 99
- autofocus 18

B

- background
 - noise 18
 - visual 18
- backlight compensation 54, 57
- bandwidth 10, 32, 101
 - dynamic 36
 - managing 34, 35, 40
- bass adjustment 62
- behavior
 - audio, designing 61
 - system, designing 70
 - video, designing 57, 58
- BRI
 - configuring 39
 - line 17
 - network cable 17, 23, 102
 - network interface module 12, 14
 - SPIDs 40
- browser requirements 30
- buddy list 67

C

- cable
 - BRI network 17, 23, 102
 - conference link 13, 25, 26, 100
 - dual display adapter 26
 - LAN 13, 23, 98, 99, 103
 - microphone pod, *see* conference link cable
 - monitor 13, 26

- call
 - diagnostics 91
 - preferences 40, 72
 - progress indicators 80, 91, 99
 - quality 40, 65, 72, 101, 102
 - speed 32, 40, 79, 91, 100
 - speed, in multipoint calls 72
 - speed, maximum 40
 - speed, optimizing 34, 35
 - statistics 79, 91, 101, 102
 - status 80, 91, 100
 - summary 78
 - time, maximum 55
 - tracking 45
 - type 40, 79, 91
 - Call Detail Report (CDR) 12, 45, 66, 71, 82–85
 - archive 85
 - calls
 - bonding 100
 - multipoint 72
 - number of 78
 - recent 81
 - summary 90
 - test 48
 - troubleshooting 98–100
 - camera
 - additional 12, 27
 - allowing far site to control 54, 57
 - autofocus 18
 - connecting 27
 - direction 57
 - document 27
 - icons 57, 69
 - input 25, 27
 - names 57, 69
 - checklist
 - ISDN network hardware 17
 - network connectivity 16
 - room setup assessment 18
 - city code 74
 - color bars test 92, 93
 - color schemes 54, 69, 71
 - conference link cable 13, 25, 26, 100
 - configuring
 - audio 61
 - dual monitor emulation 58
 - firewall 38
 - ISDN BRI 39
 - monitors 58, 101
 - NAT 37, 38
 - PIP 54, 58
 - video 57
 - connecting
 - camera 27
 - DVD or VCR 28, 102
 - microphone pods 23, 25
 - monitors 23, 26
 - network interface module 23
 - projector 26
 - subwoofer 24
 - system 23
 - Visual Concert VSX 26
 - connection
 - directory server 90
 - IP network 18, 90, 98, 99
 - ISDN network 18, 90, 99
 - network interface 22
 - power 18, 24, 25, 96
 - time server 90
 - controlling cameras 102
 - cord, power 25, 96
 - country code 74
 - country selection 74
 - customizing 11
 - appearance 63
 - Home screen 64
 - system behavior 55
- ## D
- data collaboration 60
 - data rate
 - audio 79, 91
 - video 79, 91
 - date and time 66, 74
 - daylight saving time 74
 - deleting
 - directory entries 71
 - local directory 95
 - system settings 95
 - designing
 - system appearance 63, 69, 71
 - system behavior 70
 - DHCP server 99, 103
 - diagnostics
 - audio meter 94, 100
 - call 91
 - near-end loop test 92
 - PING test 92, 98

- speaker test 93, 100
- summary 89
- video color bars test 92, 93

dialing

- options 65
- prefix, international 43
- rules 43, 98

Diffserv 36

directory

- allowing access 65
- deleting entries 71
- editing 71
- features 11, 12
- Global 23
- local, deleting 95
- server 41, 44

displaying

- Asian fonts 23
- date and time 66
- files from a computer 58, 60
- icons, in calls 58
- system name 66
- time in call 71, 74

DNS name 31

DNS server 31

Do Not Disturb 66, 73

document camera 27

documentation for users 75

dual monitor emulation 10

DVD 14

- connecting 28, 102
- inputs 25, 28
- selecting 102
- testing 94
- troubleshooting 102

dynamic bandwidth 36, 101

See also Quality of Service

E

E.164

- alias 35
- extension 33, 34, 35

echo 101

extension

- E.164 33, 34, 35
- H.323 33, 34, 35, 43, 65

external audio system, *See* audio system

F

- far control of near camera 54, 57

far site

- audio, testing 94
- system information 79
- system name 54, 71

firewall 16, 38, 103

See also NAT and security

fixed ports 37, 38

FTP access 85

G

- gatekeeper 16, 33, 34, 98

- gateway 31, 33, 35, 98

- giving instructions 68

- Global Address Book, *see* Global Directory

- Global Directory 23

- Global Directory Server 41, 44

- Global Management System 45

See also remote management

- Global Services 41–47

- graphics 58, 60

H

H.323

- extension 33, 34, 35, 43, 65
- name 33, 34

help

- from GMS administrator 46
- on-screen 68, 75

Home screen options

- multipoint 65
- speed dial 66, 67

host name 31

I

icons

- camera 57, 69
- displaying 58

indicators

- call progress 80, 91, 99
- system 104

infrared sensor 97

initial system configuration 29, 30

inputs

- audio 61
- camera 25, 27
- conference link (microphone pods, Visual Concert VSX) 22, 23
- DVD/VCR 25, 28

installing

- camera 27
- feet 20
- microphone pods 23, 25
- monitors 23, 26
- network interface module 19
- subwoofer 24
- system 23
- Visual Concert VSX 26

instructions, on-screen 68

internal multipoint option, *See* multipoint option

international dialing prefix 43

IP

- address 16, 31, 99
- address, displaying 66
- address, gatekeeper 34
- address, obtain automatically 31
- calls, allowing 31, 33
- configuring 98
- connection 99
- network connection 18, 98

IP precedence 36

ISDN

- address 16
- calls, allowing 39
- channels dialed in parallel 39
- connection 99
- connectivity, auto-detect 39
- dialing rules 43
- line provisioning 99
- line signaling protocol 99
- network connection 18
- network hardware requirements 17, 19
- numbers 99, 102
- numbers, displaying 66
- private network 42
- switch protocol 16, 39, 40, 98, 100

J

jitter 79

K

- keypad, audio confirmation 54, 71
- kiosk mode 52, 55, 64

L

LAN

- cable 13, 23, 98, 99, 103
- port 22
- properties, configuring 31
- speed 32

language selection 74

lighting 18

limiting user access 71

line signaling protocol, ISDN 99

location settings

- area code/city code 74
- country code 74
- daylight saving time 74
- time difference from GMT 74

M

main monitor 20, 58

managing bandwidth 34, 35, 40

marquee text 68

master audio volume 62

meeting password 54, 73

microphone pods 13, 100

- additional 14, 18, 23, 25
- connecting 23, 25
- positioning 18, 21, 23, 26, 101
- testing 94

mixed calls, allowing 55, 70

monitors

- additional 12, 14, 26
- cable 13, 26
- configuring 58, 101
- connecting 23, 26, 101
- for displaying files from a computer 26, 58
- main 20, 58
- NTSC 23
- outputs 22, 28
- PAL 23
- positioning 20
- troubleshooting 101
- VGA 26, 58
- volume 101

MP Plus, *See* multipoint option
 multipoint calls 11, 72
 button, adding 65
 statistics 91
 multipoint option 11
 multipoint software key 72
 muting auto-answer calls 54
 My Contacts list 66

N

name
 camera 57, 69
 DNS 31
 far site 54
 far-site system 71
 H.323 33, 34
 host 31
 system 16, 66, 70
 NAT 37, 38
 See also firewall
 near-end loop test 92
 network connectivity checklist 16
 network diagnostics 92
 network interface connection 22
 network interface module
 connecting 23
 installing 19
 Quad BRI 12, 14, 17
 NT-1 device 17, 19, 99
 see also ISDN network hardware requirements

O

option
 multipoint 11, 72
 Quad BRI network interface module 12, 14
 out-of-box setup 29, 30
 outputs
 monitor 22, 28
 subwoofer 22
 VGA 25, 26, 60
 video 61

P

packet loss 79
 password

 administrator 53, 73, 95, 103
 Global Directory 41
 meeting 54, 73
 PBX 42
 People+Content 60
 PING test 92, 98
 PIP, configuring 54, 58
 ports
 fixed 37, 38
 LAN (Ethernet) 12, 22
 positioning
 microphone pods 18, 21, 23, 26, 101
 monitors 20
 subwoofer 21
 system 20
 Visual Concert VSX 23, 26
 power
 connection 18, 24, 25
 cord 24, 25, 96
 supply 12, 96, 100
 switch 24, 25, 96
 PowerCam 14
 preferences
 call 40
 preventing
 audio feedback 21
 security issues 18, 38
 private network 42
 projector 14, 26
 Pro-Motion™ 10, 57
 See also video quality
 protocol
 audio 79, 91
 ISDN line signaling 99
 ISDN switch 39, 40, 98, 100
 video 79, 91

Q

Q.850 cause codes 99
 Quad BRI network interface module 14, 17, 23
 quality
 audio 10, 21, 101
 call 40, 65, 72, 101, 102
 video 10, 23, 101, 102
 Quality of Service 36, 101

R

- recent calls 66, 71, 81
 - see also* Call Detail Report (CDR)
- recommendations, site 18, 21
- registration, gatekeeper 33
- remote access, allowing 73
- remote control 11, 13, 97
 - batteries 24, 97, 102
- remote management 12
- removing features 65
- requirements, web browser 30
- reset system 95
- resolution, VGA graphics 26
- ring tones 61, 69
- room
 - acoustics 18
 - layout 20
 - lighting 18
- routing cables 18

S

- screen saver 68, 71
- security 18, 38
- sending a message via VSX Web 88
- serial number 95, 103
- servers
 - DHCP 99, 103
 - directory 41, 44
 - DNS 31
 - time 74
 - WINS 31
- sharing files 60
- site buttons, adding 67
- site recommendations 18, 21
- sleep mode 101, 104
- snapshots 58
- software key
 - multipoint 72
- software update 23, 96
- sound effects 61
- speaker 62
- speaker test 93, 100
- speed dial 66, 67
- speed, call 32, 40, 79, 91
- SPIDs 16, 40, 99
- split-screen, *See* dual monitor emulation

- status notifications 90
- subnet mask 31, 103
- subwoofer 13, 62, 100
 - connecting 24
 - installing network interface module 19
 - positioning 21
 - power cord 25, 96
 - power supply 96
 - volume offset 62
- switch protocol, ISDN 39, 40, 98, 100
- switch, power 24, 25, 96
- system
 - connecting 23
 - management 103
 - name 16, 66, 70
 - positioning 20
 - reset 95
 - settings, deleting 95
 - status 90
- system setup wizard 12, 29, 30

T

- technical support 105
 - from GMS administrator 46, 47
 - information to provide 105
 - telephone number 105
 - Web page address 105
- test
 - audio inputs 94
 - color bars 92, 93
 - near-end loop 92
 - PING 92, 98
 - speaker 93, 100
- test calls 48
- time and date 66, 74
- time difference from GMT 74
- time server 74
- tones
 - alert 61, 69
 - ring 61, 69
- tracking calls 45
- treble adjustment 62

U

- user limitations 55, 65, 71
 - allow directory updates 71
 - allow mixed calls 70

- maximum call speed 40
 - maximum call time 70
- user preferences 54
- user settings
 - auto-answer 54
 - backlight compensation 54
 - color schemes 54, 69
 - far control of near camera 54
 - PIP adjustment 54
- user skill levels
 - advanced users 52, 64
 - infrequent users 52, 64
 - new users 52, 64

V

- VCR 14
 - connecting 28, 102
 - inputs 25, 28
 - selecting 102
 - testing 94
 - troubleshooting 102
- VGA
 - monitor 26, 58
 - output 25, 26, 60
 - resolution 26, 60
- video
 - configuring 57
 - data rate 79
 - diagnostics 92, 93
 - outputs 61
 - protocol 79, 91
 - quality 10, 23, 101, 102
 - troubleshooting 101, 102
- visual background 18
- Visual Concert VSX 10, 14, 60
 - as a LAN hub 26
 - connecting 26
 - positioning 23, 26
 - VGA output resolution 26
- volume
 - alert tones and sound effects 101
 - bass 62
 - master control 62
 - setting 62
 - subwoofer 62
 - treble 62
- VSX Web interface 23
- VSX Web interface access 82, 103

W

- web browser requirements 30
- WINS name resolution 31
- WINS server 31